

COVAL

vacuum managers

CTC

High-Performance Bell-type Suction Cups

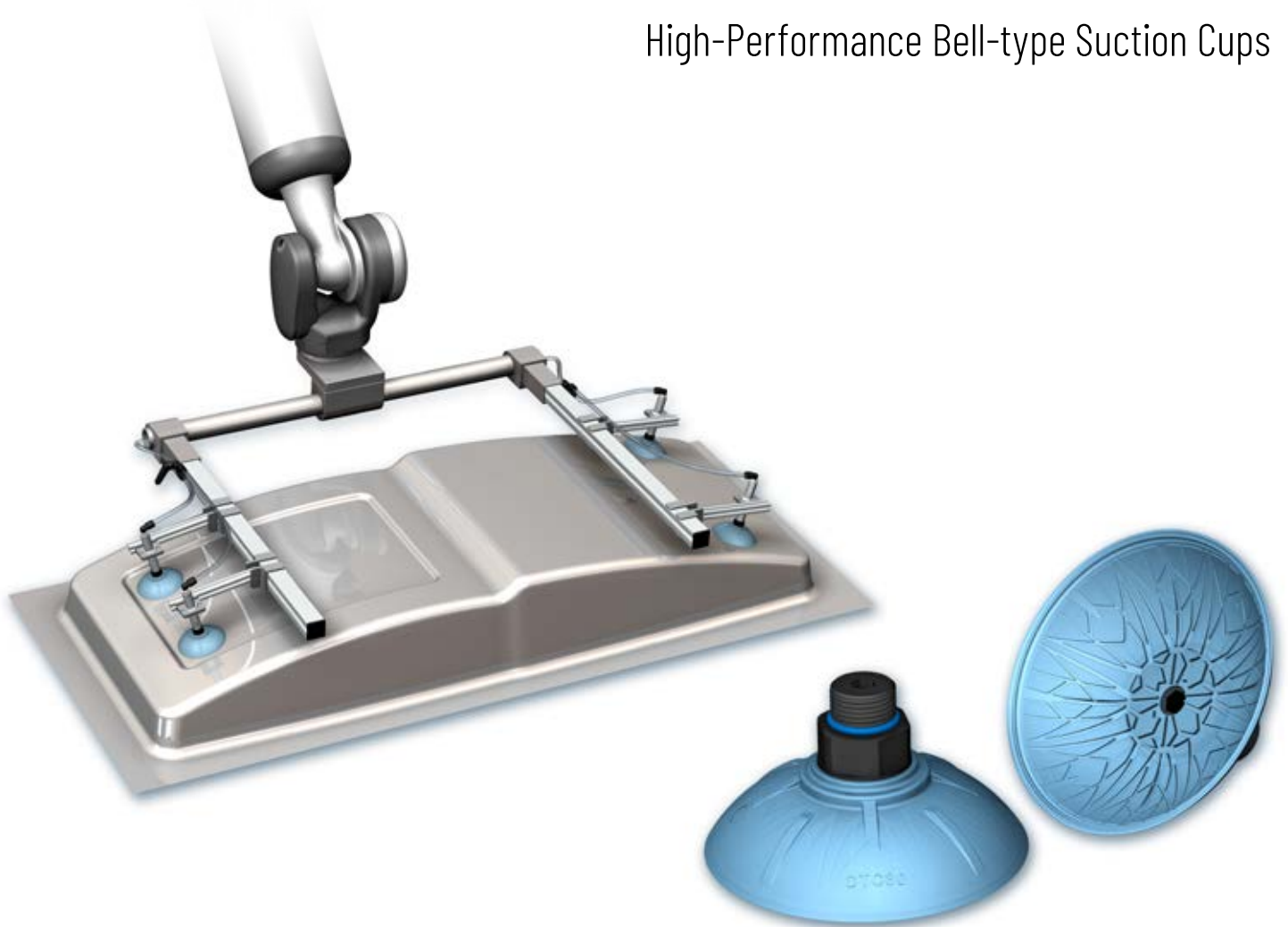

ADVANCED VACUUM SOLUTIONS

www.coval.com

EN1

High-Performance Bell-type Suction Cups



The **CTC Series** high-performance bell-type suction cups have been specifically developed to meet the production requirements of applications in the automotive sector.

The bell shape of the **CTC Series** suction cups gives them significant deflection compared to traditional flat suction cups and guarantees better adaptability to the profiles of parts with long lines. The internal stops ensure excellent sliding resistance and allow the gripping of parts without deformation.

The characteristics of the **CTC Series** suction cups optimize production in all areas of operation.

Industry-specific applications

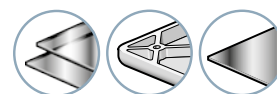

Types of use

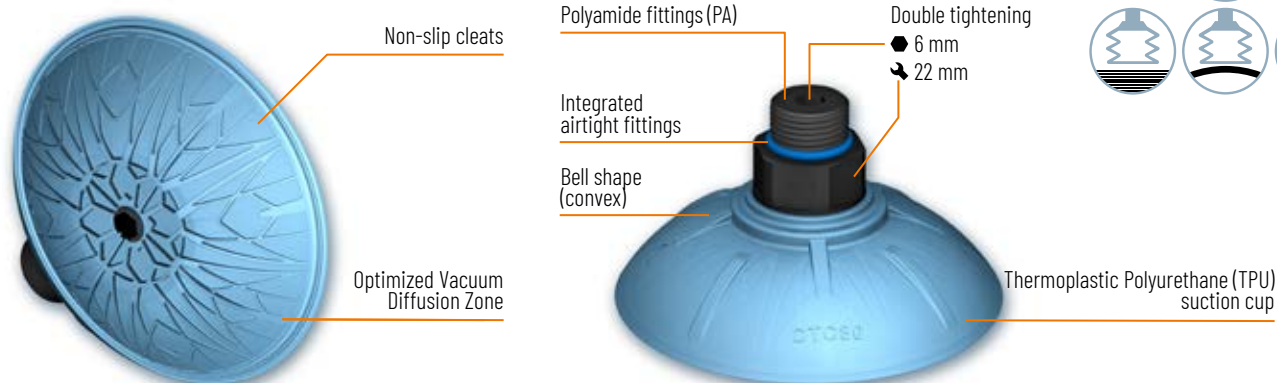
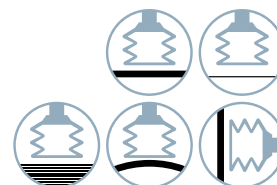

Advantages

- Extreme resistance to slippage and acceleration.
- Excellent adaptation to convex surfaces and angular shapes.
- High deflection compared to standard flat suction cups due to the bell shape.
- Anti-slip cleats ensure precise positioning of oily sheets.
- Particularly suitable for use on high-speed presses, for high speeds and handling of large parts (e.g. body side, roof, doors).
- Deformation-free gripping of thin sheets thanks to central stops.
- 4 diameters for optimal adaptation to each application.
- Excellent resistance to wear and oil thanks to thermoplastic polyurethane (TPU).
- Low weight due to polyamide insert.
- Sealing lips.
- Integrated O-ring seal (male cylindrical G3/8" and square 32 versions).
- Double tightening: 2 flat 22 mm and one hollow hexagonal 6 mm.

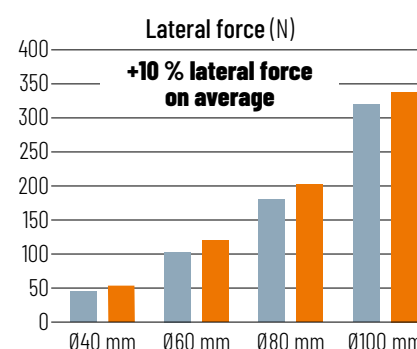
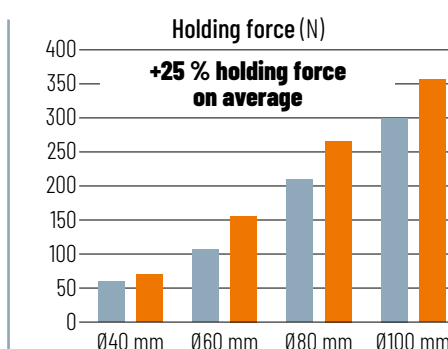
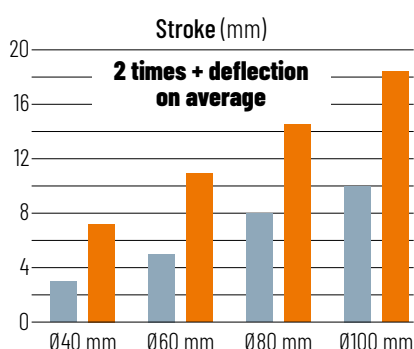

■ Standard suction cups ■ CTC Series

Application Fields

The extreme resistance to slippage and acceleration of the COVAL **CTC Series**, as well as their very low weight, make them particularly well suited for high-speed applications on robots.

The **CTC Series** are dedicated to the handling of sheet metal, glass, and plastics in industries such as stamping, metal forming, mirror manufacturing, and assembly.





Fittings

M38G

Male fitting G3/8"
(polyamide insert)



F38G

Female fitting G3/8"
(polyamide insert)



C32

Square coupling 32 mm
(polyamide fitting and 32mm square in aluminum)



Other fittings available upon request

Characteristics

(1) Force measured at 65% on dry, smooth, and flat sheet metal, without safety coefficient. (2) f = deflection of the suction cup Note: all dimensions are given in mm.

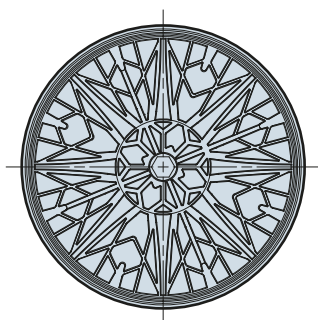

	Ø A At rest	Ø A gripping	Volume (cm ³)	Force (N) ⁽¹⁾	Force (N) ⁽¹⁾	Rmin	Ø bore	tightening
CTC 40	43.5	47.6	8.1	70	53	18	6.3	w 22 + hk 6
CTC 60	64.7	71.7	26.1	156	120	24	6.3	w 22 + hk 6
CTC 80	84.1	92.7	72.1	266	202	36	6.3	w 22 + hk 6
CTC 100	106	115.6	103.4	356	338	40	6.3	w 22 + hk 6

	H1	f ⁽²⁾	G1	G1'	Ø D	Weight (g)		
						F38G	M38G	C32
CTC 40	30	7.2	10.5	10.7	32.8	12.9	17.9	35.1
CTC 60	33.9	10.9	10.5	10.7	32.7	18.3	23.3	40.5
CTC 80	36.5	14.5	10.5	10.7	33.3	26.9	31.9	49.1
CTC 100	39.1	18.4	10.5	10.7	40.3	36.1	41.1	58.3

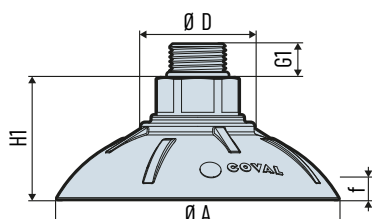

M38G Male fitting G3/8"

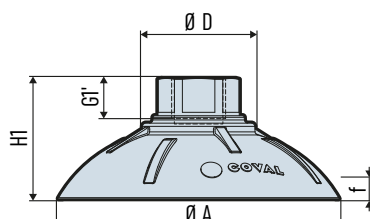

F38G Female fitting G3/8"

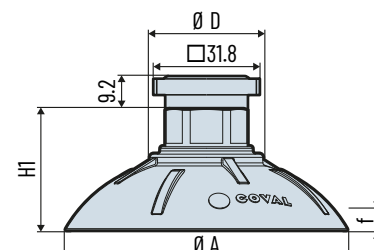

C32 Square coupling 32

Materials

SUCTION CUPS

- TPU: Thermoplastic polyurethane, 85 shore A**
 - High resistance to oils and abrasion.
 - Operating temperature from -20° to 100°C (up to 120°C peak).

FITTINGS

- PA: Polyamide filled with fiberglass (PA 6.6 30% FG)**, (fitting M38G/F38G).
- AL: Aluminum** (M38GA/F38GA/C32 Fitting).
- O-ring** (for M38G and C32 fittings): NBR Nitrile Blue.

CTC 80 TPU M38G

DIAMETER		FITTING
Ø 40 mm	40	M38G G3/8"-M
Ø 60 mm	60	F38G G3/8"-F
Ø 80 mm	80	C32 C32
Ø 100 mm	100	

Example:
CTC80TPUM38G

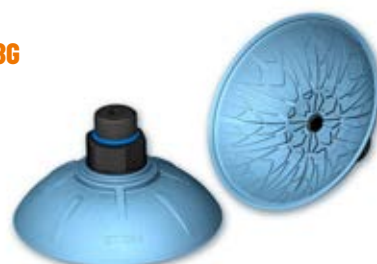



COVAL
vacuum managers

vacuum
components



A TECHNOLOGICAL PARTNER ON A GLOBAL SCALE

Located in the southeast region of France, COVAL conceives, manufactures and globally distributes high performance, advanced vacuum automation components and systems for industrial applications in all branches.

COVAL is an ISO 9001: V2015 certified company which offers innovative solutions integrating reliable and optimized components with intelligent functionalities. The focus is to provide the most personalized and economic solution to a given application while assuring a significant improvement in the productivity and the safety for the vacuum users around the world.

COVAL has an ambition for technical excellence and innovation. As a specialist in vacuum automation, COVAL is reputed for offering reliable, personalized, cost effective and productive solutions.

The references of COVAL can be found in several industrial sectors (Packaging, Automotive Industry, Plastic, Graphic, Aeronautic...) where vacuum handling is important for high efficiency and productivity.

COVAL markets its products and services all over Europe, in the United States and South America through its subsidiaries and authorized distribution network. COVAL strives to provide customer driven solutions and gives the best possible treatment to satisfy all its clients.

For all enquiries from Australia, Africa and Asia kindly contact COVAL head office in France.



COVAL S.A.S.

Head Office



COVAL INC.



COVAL IBERICA



COVAL GERMANY



COVAL ITALIA



COVAL CHINA

Distributed by:



certified quality
management system

COVAL S.A.S.

Head Office
ZA Les Petits Champs
10 allée Jean-Baptiste Venturi
26120 Montélier France
Tel: +33 (0)4 75 59 91 91
Fax: +33 (0)4 75 59 91 05

www.coval.com