

EN

OPERATING INSTRUCTIONS

CVGC-UR (v05-2023)

This manual is intended for users of carbon vacuum grippers, **CVGC** series.

You will find the necessary information for the integration of the grippers on the cobots, as well as for their use and maintenance.

For further information, please contact COVAL:

Mail: coval@coval.com

Phone: +33 (0)4 75 59 91 91



UNIVERSAL ROBOTS+
Certified

In the case of integration on a collaborative robot, Universal Robots (e-Series), the download of the URCap plugin is on our web site: <https://doc.coval.com/CVGC-UR>

Here you will find instructions for installing and programming the URCap plugin.

SUMMARY

- I. Composition
- II. Dimensions / Centers of gravity
- III. Mounting interface (ISO 9409-1)
- IV. Electrical connections
- V. Inputs/outputs switching mode
- VI. Supply and pneumatic connection of vacuum grippers
- VII. Installation instructions
- VIII. General characteristics
- IX. Use and Application
- X. Maintenance
- XI. Vacuum gripper airtight leak test
- XII. Related documents to be downloaded

 Retrouvez tous les documents en différentes langues sur le site coval : <https://doc.coval.com/CVGC-UR>

 Please find all the documents in different languages on the coval website: <https://doc.coval.com/CVGC-UR>

 Finden Sie alle Dokumente in verschiedenen Sprachen auf der COVAL-Homepage: <https://doc.coval.com/CVGC-UR>

 Tutti i documenti nelle differenti lingue sono presenti sul sito Coval: <https://doc.coval.com/CVGC-UR>

 Podrá encontrar todos los documentos en diferentes idiomas en la página web de coval: <https://doc.coval.com/CVGC-UR>

With their innovative design, Coval's **CVGC** carbon vacuum grippers correspond perfectly to the weight constraints, flexibility and safety of collaborative robot applications.

The **CVGC** series is composed of:

- a carbon structure, 2.5 times lighter than aluminum and offering mechanical strength 6 times greater
- flexible material on the gripper edges, to protect both gripper and operator

- foam gripping interface, for versatile product handling
 - a plastic "function" block, including vacuum generator, pilot control cartridge, silencer and vacuum switch...
- ... all this, in a very compact and ultralight design, guarantees a fast setup and easy integration on the robot.

The three standard formats allow you to choose your **CVGC** and ensure the handling of your loads: corrugate, plastics, metal/glass plates, etc.

REMINDER OF POSSIBLE CONFIGURATIONS:

CVGC	240X120	A50	C1
DIMENSIONS		ISO 9409-1 ROBOT MOUNTING INTERFACE	ELECTRICAL CONNECTIONS
150 x 150 mm	150X150	A50 ISO 9409-1-50-4-M6	C1 M8 - Female 8-pins
240 x 120 mm	240X120		
320 x 160 mm	320X160		

I. COMPOSITION

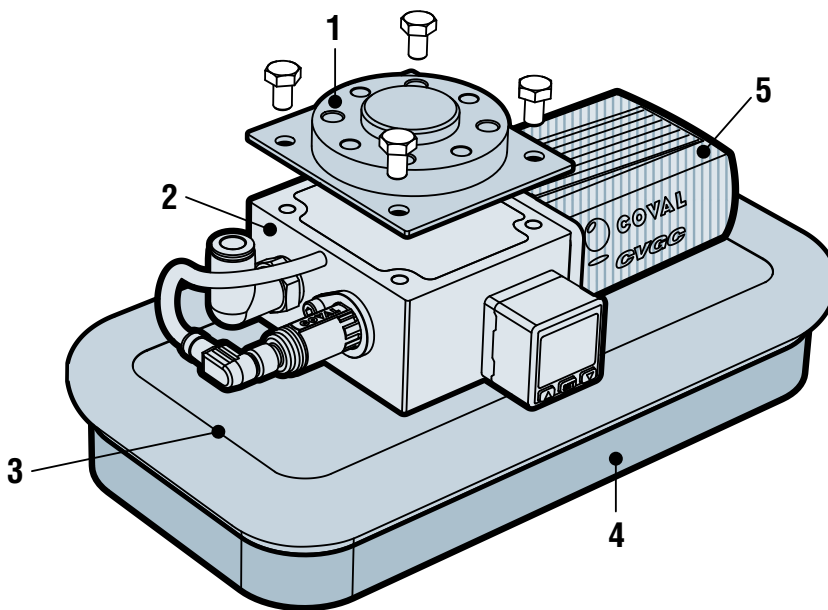

Ref.	Designation	CVGC150x150A50C_	CVGC240x120A50C_	CVGC320x160A50C_
1	Mounting interface type A50 (ISO 9409-1-50-4-M6)		80004902	
2	Function block (vacuum generator, control, electronic vacuum switch, silencer)			
	Electrical connection version C1	VBC1XC1	VBC2XC1	VBC3XC1
3	Carbon structure + foam protection	80004901	80004914	80004918
4	Foam gripping interface	80005296	80005297	80005298
5	Silencer	/	80005226	80005226

II. DIMENSIONS / CENTER OF GRAVITY

II.1 Dimensions

CVGC150X150A50C1

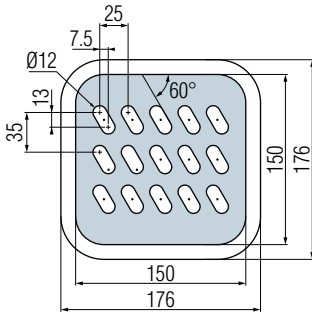

CVGC240X120A50C1

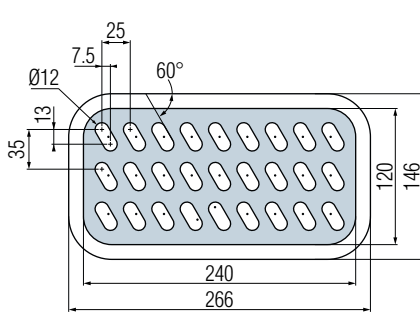

CVGC320X160A50C1

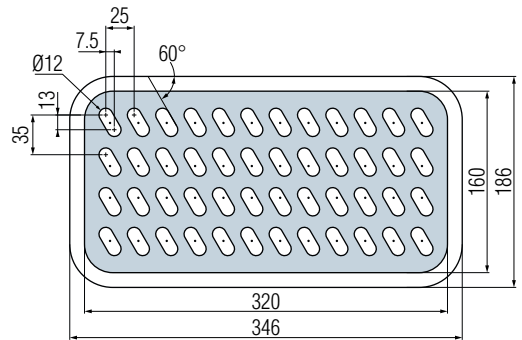

Mounting interface A50

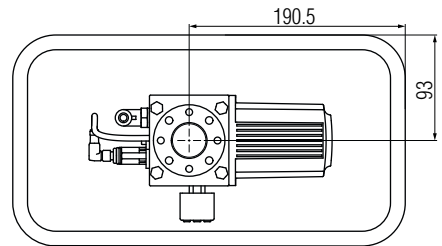
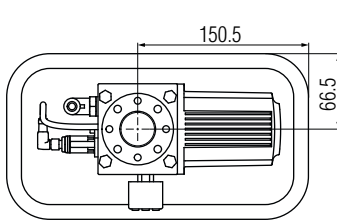
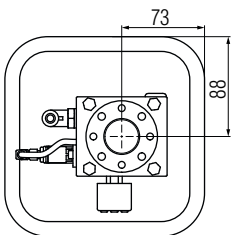
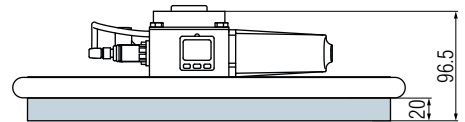
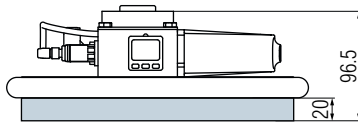
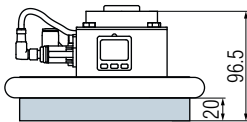

Note: All dimensions are in mm.

II.2 Centers of gravity

CVGC150X150A50C1

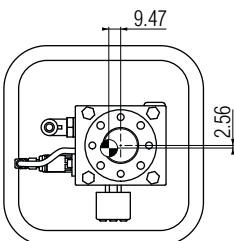
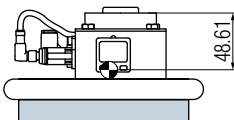

CVGC240X120A50C1

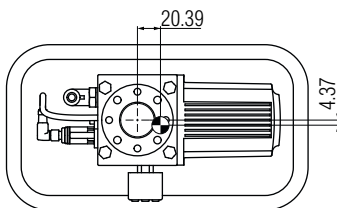
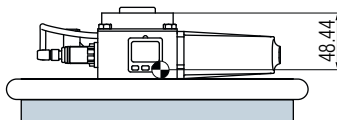

CVGC320X160A50C1

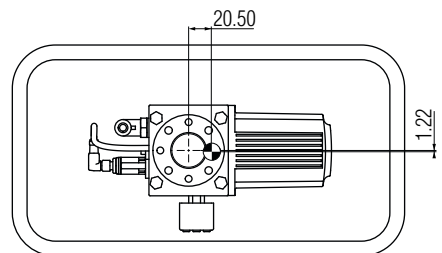
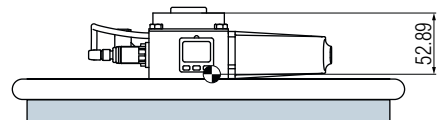

Note: All dimensions are in mm.

III. MOUNTING INTERFACE (ISO 9409-1)

Version	Standard	Ø A (mm)	Ø B (mm)	Ø C (mm)	Ø D (mm)	Ø E (mm)	
A50	ISO 9409-1-50-4-M6	50	63	M6 (4 screws)	6	31.5	Universal Robots UR3, UR5, UR10, UR16 + e-Series

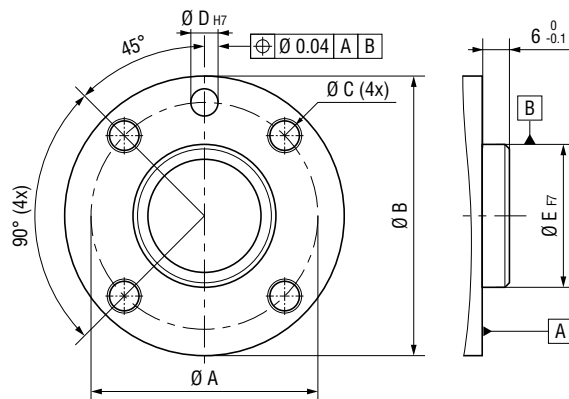

IV. ELECTRICAL CONNECTIONS

CVGC Carbon Vacuum Grippers must be used with power supply units that provide a Protective Extra Low Voltage (PELV) and with an isolation of the supply voltage according to EN60204.

IV.1 Electrical characteristics

- Control voltage: 24 V DC +/-10%
- Vacuum control: 24 V DC PNP/NPN
- Power consumption: 65 mA max. (no load)
- The switching type of the inputs / outputs is configurable to PNP or NPN
- Outputs (see detailed instructions for the PSD100CPNP electronic vacuum

switch):

- 1 x "Vacuum level" signal analogic 1 to 5 V DC
- 1 x "Gripped product" switching output 24 V DC PNP/NPN NO or NC (125 mA max.)

IV.2 Electrical connections

- **C1:** M8 connector - female 8-pins elbow, cable length 150 mm

 Universal Robots CB3 UR3, UR5, UR10
+ e-Series UR3e, UR5e, UR10e, UR16e (URCap plugin available)

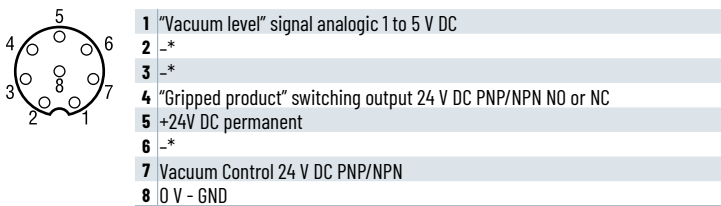

* not used in this configuration

V. INPUTS/OUTPUTS SWITCHING MODE

The CVGC's input/output signals can be configured in PNP (switching to positive potential charge) or NPN (switching to negative potential charge) to adapt to characteristics of the robot/controller used.

 **The mode change must be performed while the power is off.**

Configuration

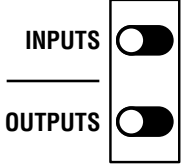
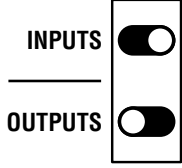
	Universal Robots e-Series UR3e, UR5e, UR10e, UR16e	Universal Robots CB3 UR3, UR5, UR10
Inputs	PNP	NPN
Outputs	PNP	PNP
		

By default, the inputs/outputs are configured PNP/PNP for the robots Universal Robots e-Series UR3e, UR5e, UR10e, UR16e.

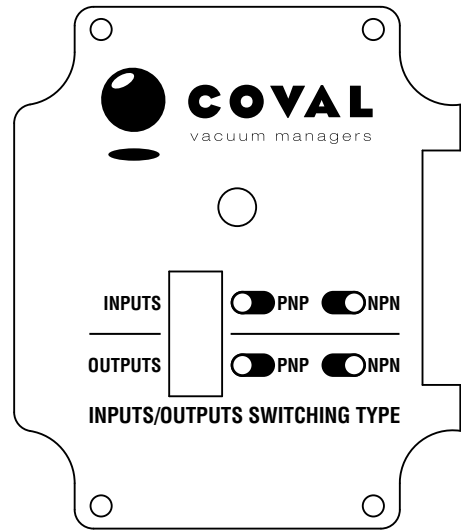

VI. SUPPLY AND PNEUMATIC CONNECTION OF VACUUM GRIPPERS

VI.1 Pneumatic supply characteristics

- Supply: non-lubricated air, 5 microns filtered, according to ISO 8573-1:2010 [4:5:4].
- Operating pressure: from 5 to 6 bar
- Optimal pressure:
 - CVGC150x150 / CVGC 320x160: 5.5 bar
 - CVGC240x120: 6 bar

	Air consumed	Air drawn in	Max. vacuum (%)	Sound level (dBA)
CVGC150X150	135 NI/min (4.77 SCFM)	90 NI/min (3.18 SCFM)	85	72
CVGC240X120	270 NI/min (9.53 SCFM)	180 NI/min (6.36 SCFM)	85	71
CVGC320X160	345 NI/min (12.2 SCFM)	210 NI/min (7.42 SCFM)	85	66

VI.2 Connection

Connect the compressed air to the push-in connector \varnothing 8 mm.

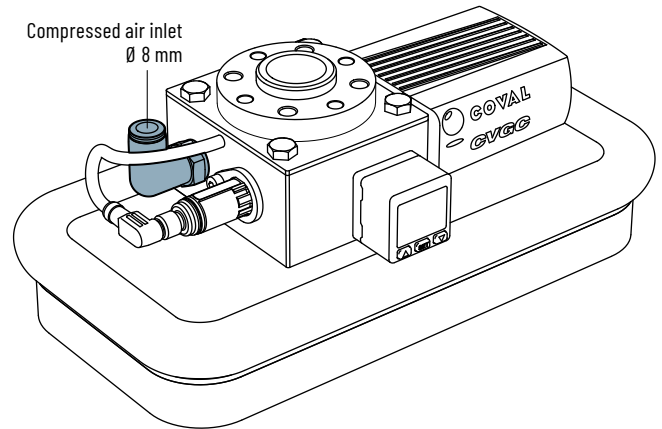

VII. ASSEMBLY INSTRUCTIONS

Note: - M6 indexing pin provided.

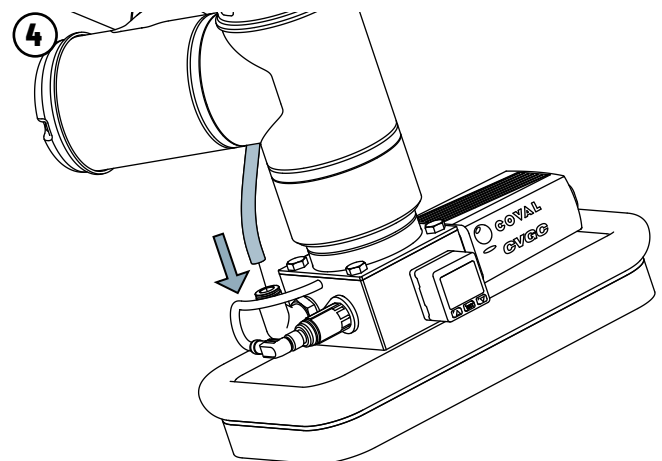
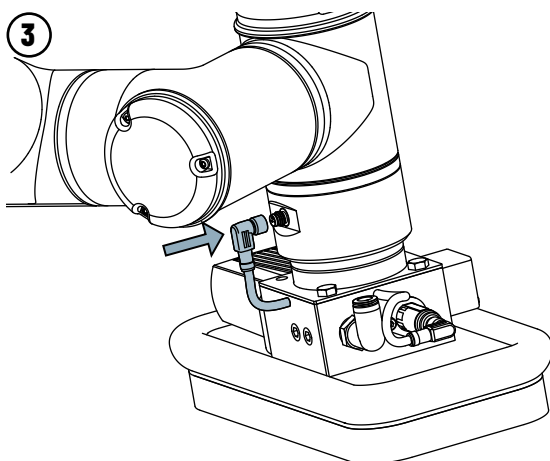
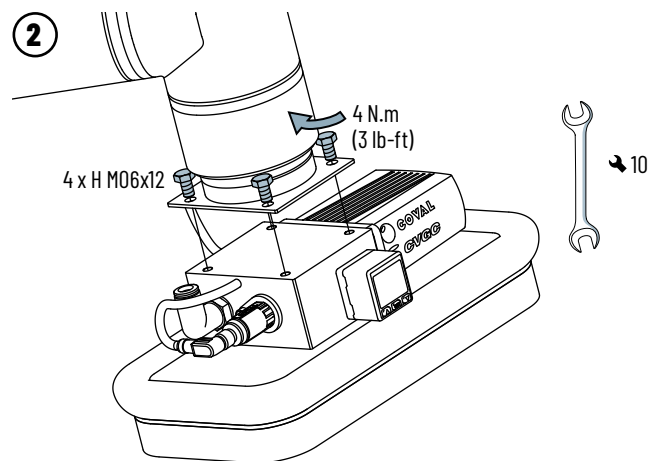
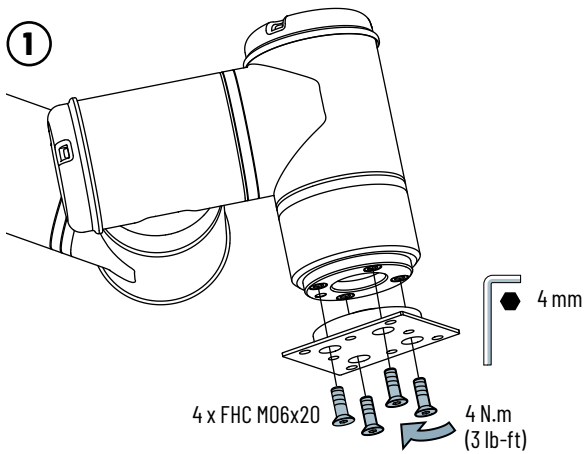

For the use of CVGC series carbon vacuum gripper on UNIVERSAL ROBOTS e-Series robots, a URcap plugin with installation and programming instructions are available for download on the COVAL website: <https://doc.coval.com/CVGC-UR>

VIII. GENERAL CHARACTERISTICS

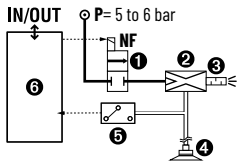

- ❶ "Vacuum" solenoid valve
- ❷ Venturi
- ❸ Through-type silencer
- ❹ Foam gripping interface
- ❺ Electronic vacuum switch
- ❻ Input / Output board

- Supply: non-lubricated air, 5 microns filtered, according to ISO 8573-1:2010 [4:5:4].
- Operating pressure: from 5 to 6.5 bar
- Optimal pressure:
 - CVGC150x150: 5.5 bar
 - CVGC240x120: 6 bar
 - CVGC 320x160: 6.4 bar
- Maximum vacuum: 85%.
- Vacuum command light: orange LED
- Electric protection grade: IP40

- Control voltage: 24 V DC +/-10%
- Vacuum control: 24 V DC PNP/NPN
- Power consumption: 65 mA (no load)
- The switching type of the inputs / outputs is configurable to PNP or NPN
- Outputs:
 - 1x "Vacuum level" signal analogic 1 to 5 V DC
 - 1x "Gripped product" switching output 24 V DC PNP/NPN NO or NC (125 mA max.)
- Service life: 30 million cycles
- Operating temperature: from 0 to 50° C (from 32 to 122° F).
- Materials:
 - Gripper: carbon, PA 6.6 15% FG, brass, stainless steel, PETP
 - Valve: aluminum, steel, NBR
 - Foam gripping interface: EPDM
- Noise level:
 - CVGC 150x150: 72 dBA
 - CVGC 240x120: 71 dBA
 - CVGC 320x160: 66 dBA

The values represent the average characteristics of our products.

IX. USE AND APPLICATION

Max. capacity

	Capacity ⁽¹⁾ (kg)	 (kg)
CVGC 150X150	30	0.8
CVGC 240X120	38	1.0
CVGC 320X160	68	1.3

(1) Indicative force for a vacuum gripper with foam interface covered 100% by the load, including a safety factor of 2 for horizontal handling and rigid, airtight surface.

Foam Interface

- Operating temperature: from -40 to 180° C (from -40 to 356° F)
- Avoid prominent shapes
- Caution: angle of approach.

Recommendation

- Cover 100% of the surface of the foam gripper interface.
- Position of the gripper:
 - Always position the gripper in the centre of the load to manipulate.
 - CVGC vacuum grippers are designed for the handling of loads in horizontal movement.
- It is not recommended to use the CVGC for vertical gripping as the foam could deteriorate quickly.
 - In the rare case of vertical use, tests should be performed prior to commercial use
 - COVAL will not be held responsible for the premature degradation of the foam.

Note: For applications with high accelerations, or a grip in vertical position, the safety factor must be calculated according to application-specific conditions.

X. MAINTENANCE

X.1 Frequency

Determination of the maintenance frequency according to the rates, the environment and the type of load.

→ To be defined by the user.

Spare parts (Order code according to CVGC model)

Ref.	Designation	CVGC150x150	CVGC240x120	CVGC320x160
1	Foam protection	80005438	80005439	80005440
2	Foam gripping interface	80005296	80005297	80005298

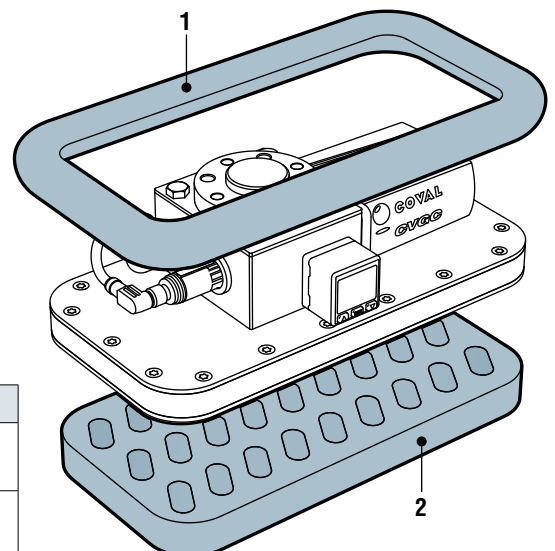

X.2 Procedure for replacing the gripping foam

1. Manually remove the used FOAM interface.

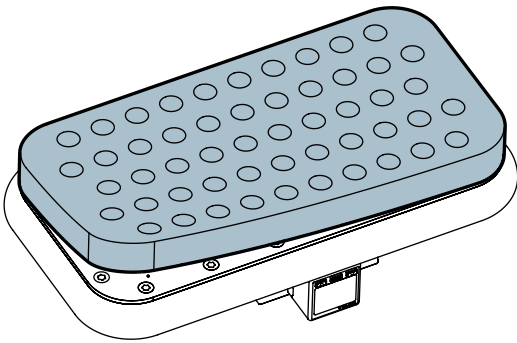

2. Clean the carbon plate with a chemical degreaser (e.g. NECTRAL) to remove unwanted compounds (adhesive residue, grease...).

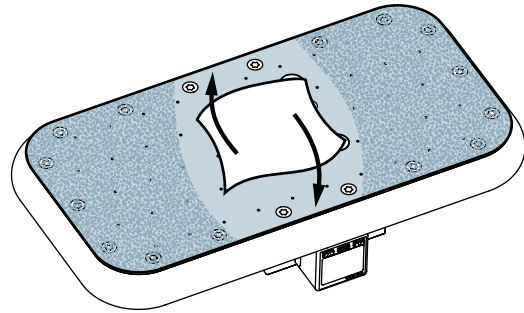

3. On the replacement foam, rub the protective film on the adhesive side for a few seconds to activate the cells and promote bonding.

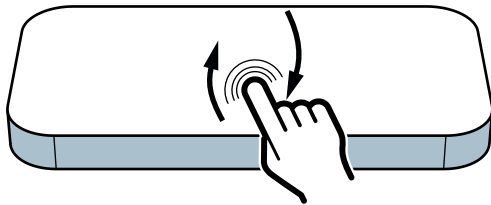

4. Remove the protective film.

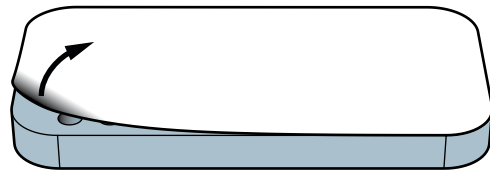

5. Adhere foam to carbon plate by aligning the holes.

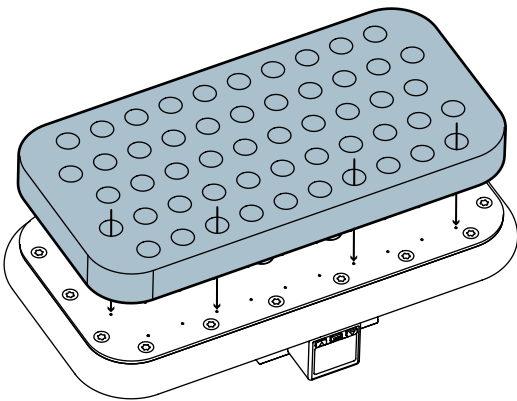

6. Turn the gripper over and place it on a flat, smooth and clean surface. Press lightly on the box for 30 seconds so that the foam is uniformly glued to the carbon plate.

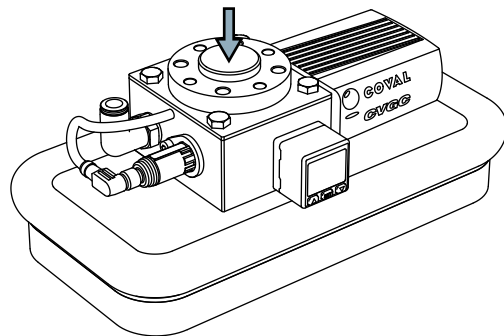

To check proper functioning of the vacuum gripper, complete airtight leak test (see chapter XI).

XI. VACUUM GRIPPER AIRTIGHT LEAK TEST

To ensure the proper functioning of the CVGC vacuum grippers after a maintenance operation, it is important to complete an airtight leak test:

1. Place the gripper on a clean, smooth, flat and waterproof surface.
2. Activate vacuum.
3. Check the vacuum level on the electronic vacuum switch. It must be at least 80% (-800 mbar) at the optimal functioning pressure of the housing.

If the vacuum level is not reached, check:

- the quality of the test surface,
- the wear of the gripping foam and its adhesive
- the size of the compressed air hose (internal Ø 6 mm minimum),
- the quality of the compressed air network (connections, pipes, leaks or damage) and replace defective components.
- the pressure of the compressed air network:
 - Optimal functioning pressure:
 - CVGC150x150 / CVGC 320x160 : 5.5 bar
 - CVGC240x120 : 6 bar

XII. RELATED DOCUMENTS TO BE DOWNLOADED

- Vacuum switch manual PSD100CPNP (<https://doc.coval.com/PSD>)
- Installation and operating instructions for the URCap plugin (<https://doc.coval.com/CVGC-UR>)

 Retrouvez tous les documents en différentes langues sur le site coval : <https://doc.coval.com/CVGC-UR>

 Please find all the documents in different languages on the coval website: <https://doc.coval.com/CVGC-UR>

 Finden Sie alle Dokumente in verschiedenen Sprachen auf der COVAL-Homepage: <https://doc.coval.com/CVGC-UR>

 Tutti i documenti nelle differenti lingue sono presenti sul sito Coval: <https://doc.coval.com/CVGC-UR>

 Podrá encontrar todos los documentos en diferentes idiomas en la página web de coval: <https://doc.coval.com/CVGC-UR>

A TECHNOLOGICAL PARTNER ON A GLOBAL SCALE

Located in the southeast region of France, COVAL conceives, manufactures and globally distributes high performance, advanced vacuum automation components and systems for industrial applications in all branches.

COVAL is an ISO 9001: V2015 certified company which offers innovative solutions integrating reliable and optimized components with intelligent functionalities. The focus is to provide the most personalized and economic solution to a given application while assuring a significant improvement in the productivity and the safety for the vacuum users around the world.

COVAL has an ambition for technical excellence and innovation. As a specialist in vacuum automation, COVAL is reputed for offering reliable, personalized, cost effective and productive solutions.

The references of COVAL can be found in several industrial sectors (Packaging, Automotive Industry, Plastic, Graphic, Aeronautic...) where vacuum handling is important for high efficiency and productivity.

COVAL markets its products and services all over Europe, in the United States and South America through its subsidiaries and authorized distribution network. COVAL strives to provide customer driven solutions and gives the best possible treatment to satisfy all its clients.

For all enquiries from Australia, Africa and Asia kindly contact COVAL head office in France.



COVAL S.A.S.

(Head Office)

Mail: coval@coval.com
Phone: +33 (0)4 75 59 91 91
www.coval.com



COVAL INC.

Mail: contact@coval-inc.com
Phone: (919) 233 4855
www.coval-inc.com



COVAL IBERICA

Mail: contacto@coval.com
Phone: (+34) 930 185 441
www.coval-iberica.com



COVAL GERMANY

Mail: kontakt@coval.com
Phone: +49 (0)7121 7999-250
www.coval-germany.com



COVAL ITALIA

Mail: coval.it@coval.com
Phone: +39 011 958 8660
www.coval-italia.com



COVAL CHINA

Mail: sales@coval.net.cn
Phone: +86 21 64295600
www.coval.net.cn