

# CVGC

## CARBON Vacuum Grippers



**EN**

### OPERATING INSTRUCTIONS

CVGC (v06-2023)

This manual is intended for users of carbon vacuum grippers, **CVGC** series. You will find the necessary information for the integration of the grippers on the cobots, as well as for their use and maintenance.

For further information, please contact COVAL:  
Mail: [coval@coval.com](mailto:coval@coval.com)  
Phone: +33 (0)4 75 59 91 91



### UNIVERSAL ROBOTS

In the case of integration on a collaborative robot, Universal Robots (e-Series), the download of the URCap plugin is on our web site:

<https://doc.coval.com/CVGC>

Here you will find instructions for installing and programming the URCap plugin.

### SUMMARY

- I. Composition
- II. Dimensions / Centers of gravity
- III. Mounting interfaces (ISO 9409-1)
- IV. Electrical connections
- V. Inputs/outputs switching mode
- VI. Supply and pneumatic connection of vacuum grippers
- VII. Assembly instructions
- VIII. General characteristics
- IX. Use and Application
- X. Maintenance
- XI. Vacuum gripper airtight leak test
- XII. Related documents to be downloaded



Retrouvez tous les documents en différentes langues sur le site coval : <https://doc.coval.com/CVGC>



Please find all the documents in different languages on the coval website: <https://doc.coval.com/CVGC>



Finden Sie alle Dokumente in verschiedenen Sprachen auf der COVAL-Homepage: <https://doc.coval.com/CVGC>



Tutti i documenti nelle differenti lingue sono presenti sul sito Coval: <https://doc.coval.com/CVGC>



Podrá encontrar todos los documentos en diferentes idiomas en la página web de coval: <https://doc.coval.com/CVGC>

With their innovative design, Coval's **CVGC** carbon vacuum grippers correspond perfectly to the weight constraints, flexibility and safety of collaborative robot applications.

- The **CVGC** series is composed of:
- a carbon structure, 2.5 times lighter than aluminum and offering mechanical strength 6 times greater
  - flexible material on the gripper edges, to protect both gripper and

- operator
  - foam gripping interface, for versatile product handling
  - a plastic "function" block, including vacuum generator, pilot control cartridge, silencer and vacuum switch...
- ... all this, in a very compact and ultralight design, guarantees a fast setup and easy integration on the robot.
- The three standard formats allow you to choose your **CVGC** and ensure the handling of your loads: corrugate, plastics, metal/glass plates, etc.

**REMINDER OF POSSIBLE CONFIGURATIONS:**

<b>CVGC</b>	<b>240X120</b>	<b>A50</b>	<b>C1</b>
<b>DIMENSIONS</b>		<b>ISO 9409-1 ROBOT MOUNTING INTERFACE</b>	<b>ELECTRICAL CONNECTIONS</b>
150 x 150 mm	<b>150X150</b>	<b>A31</b> ISO 9409-1-31.5-4-M5	<b>C1</b> M8 - Female 8-pins
240 x 120 mm	<b>240X120</b>	<b>A50</b> ISO 9409-1-50-4-M6	<b>C2</b> M8 - Male 5-pins
320 x 160 mm	<b>320X160</b>		<b>C3</b> M8 - Male 8-pins
			<b>C4</b> Wire outlet 2 m.
			<b>C5</b> Wire outlet 5 m.
		<b>A63</b> ISO 9409-1-63-4-M6	<b>C6</b> Molex connector 8-pins

**I. COMPOSITION**

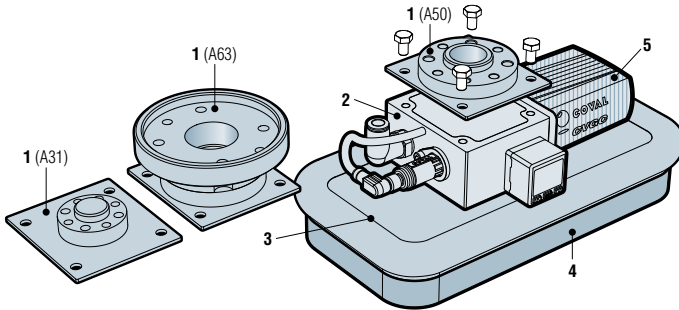

Ref.	Designation	CVGC150x150...	CVGC240x120	CVGC320x160
1	Mounting interface type A31 (ISO 9409-1-31.5-4-M5)		80004902	
	Mounting interface type A50 (ISO 9409-1-50-4-M6)		80004903	
	Mounting interface type A63 (ISO 9409-1-63-4-M6)		80004905	
2	Function block (vacuum generator, control, electronic vacuum switch, silencer)			
	Electrical connection version C1	VBC1XC1	VBC2XC1	VBC3XC1
	Electrical connection version C2	VBC1XC2	VBC2XC2	VBC3XC2
	Electrical connection version C3	VBC1XC3	VBC2XC3	VBC3XC3
	Electrical connection version C4	VBC1XC4	VBC2XC4	VBC3XC4
	Electrical connection version C5	VBC1XC5	VBC2XC5	VBC3XC5
	Electrical connection version C6	VBC1XC6	VBC2XC6	VBC3XC6
3	Carbon structure + foam protection	80004901	80004914	80004918
4	Foam gripping interface	80005296	80005297	80005298
5	Silencer	/	80005226	80005226

**II. DIMENSIONS / CENTERS OF GRAVITY**

**II.1 Dimensions**

**CVGC150X150A----**

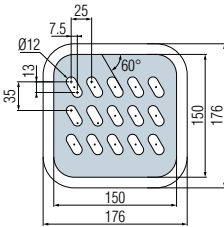

**CVGC240X120A----**

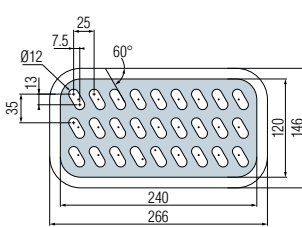

**CVGC320X160A----**

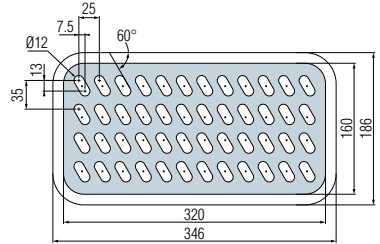

**Mounting interfaces A31 or A50**

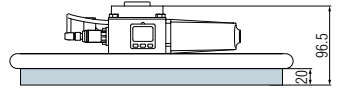
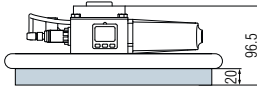
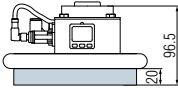

**Mounting interface A63**

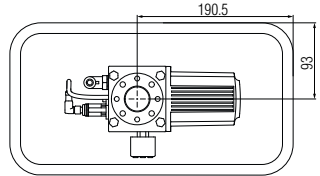
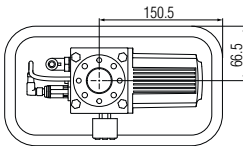
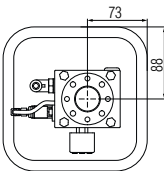
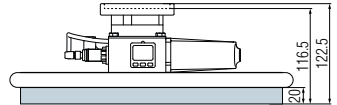
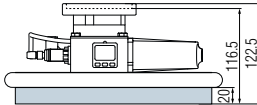
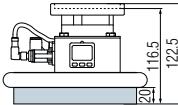

Note: All dimensions are in mm.

**II.2 Centers of gravity**

**CVGC150X150A31...**

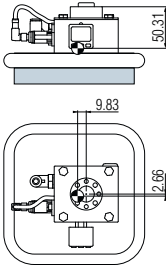

**CVGC240X120A31...**

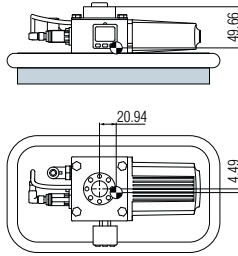

**CVGC320X160A31...**

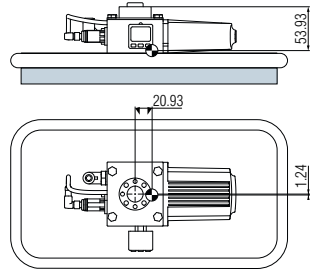

**CVGC150X150A50...**

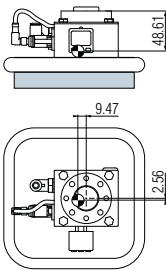

**CVGC240X120A50...**

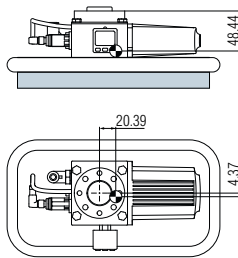

**CVGC320X160A50...**

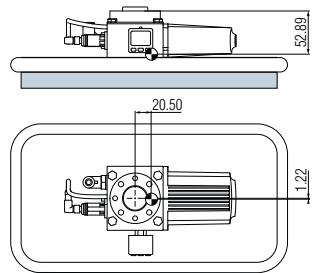

**CVGC150X150A63...**

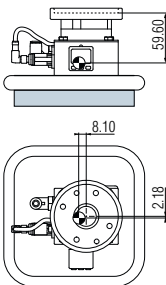

**CVGC240X120A63...**

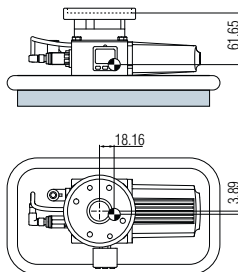

**CVGC320X160A63...**

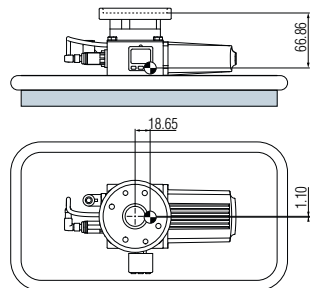

Note: All dimensions are in mm.

**III. MOUNTING INTERFACES (ISO 9409-1)**

Version	Standard	Ø A (mm)	Ø B (mm)	Ø C (mm)	Ø D (mm)	Ø E (mm)	
A31	ISO 9409-1-31.5-4-M5	31.5	40	M5 (4 screws)	5	20	Fanuc CR-4, CR-7, CR-7 A/L, CR-14 A/L
A50	ISO 9409-1-50-4-M6	50	63	M6 (4 screws)	6	31.5	Universal Robots UR3, UR5, UR10, UR16 + e-Series Omron/Techman TM5, TM12, TM14 Doosan Robotics M0609, M0617, M1013, M1509, H2017, H2515 Fanuc CRX10-IA
A63	ISO 9409-1-63-4-M6	63	80	M6 (4 screws)	6	40	Yaskawa HC10, HC10DT

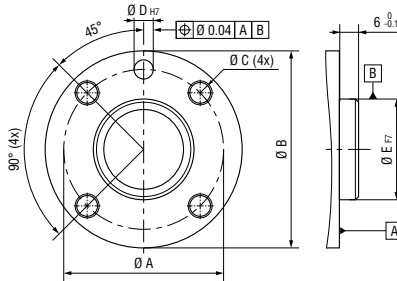

**IV. ELECTRICAL CONNECTIONS**

**CVGC Carbon Vacuum Grippers must be used with power supply units that provide a Protective Extra Low Voltage (PELV) and with an isolation of the supply voltage according to EN60204.**

**IV.1 Electrical characteristics**

- Control voltage: 24 V DC +/-10%
- Vacuum control: 24 V DC PNP/NPN
- Power consumption: 65 mA max. (no load)
- The switching type of the inputs / outputs is configurable to PNP or NPN

- Outputs (see detailed instructions for the PSD100CPNP electronic vacuum switch):
  - 1x "Vacuum level" signal analogic 1 to 5 V DC
  - 1x "Gripped product" switching output 24 V DC PNP/NPN NO or NC (125 mA max.)

**IV.2 Electrical connections depending on the version**

- **C1:** M8 connector - female 8-pins elbow, cable length 150 mm

 Universal Robots CB3 UR3, UR5, UR10 + e-Series UR3e, UR5e, UR10e, UR16e (URC plug-in available) / Fanuc CRX10-IA

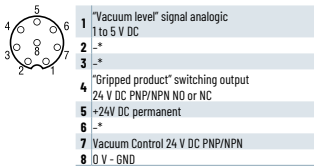

\* not used in this configuration

- **C2:** M8 connector - male 5-pins elbow, cable length 150 mm

 Omron/Techman TM5, TM12, TM14

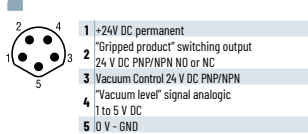

- **C3:** M8 connector - male 8-pins elbow, cable length 150 mm

 Doosan Robotics M0609, M0617, M1013, M1509, H2017, H2515

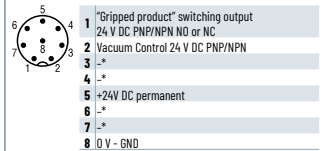

\* not used in this configuration

- **C4 / C5:** 5-wire output, cable length 2 m (C4) or 5 m (C5)

 Fanuc CR-4, CR-7, CR-7, CR-7 A/L, CR-14 A/L  
+ any application requiring cables to be routed outside the robot arm + any robot whose housing connection does not match C1/C2/ C3/C6.

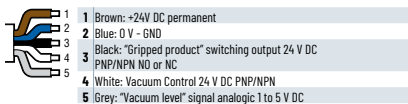

- **C6:** Molex 8-pole connector, 50 mm long cable.

 Yaskawa HC10, HC10DT (+ analog I/O card if required).

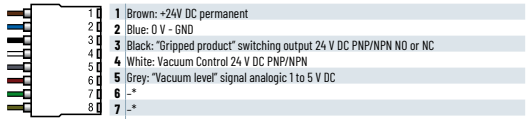

\* not used in this configuration

**V. INPUTS/OUTPUTS SWITCHING MODE**

The CVGC's input/output signals can be configured in PNP (switching to positive potential charge) or NPN (switching to negative potential charge) to adapt to characteristics of the robot/controller used.

 **The mode change must be performed while the power is off.**

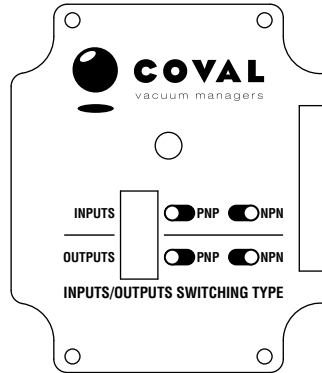



By default, the inputs/outputs are configured:

- PNP for versions C1,C3,C4 and C5
- NPN for versions C2 and C6

Version	C1/C3/C4/C5	C2/C6
Inputs	PNP	NPN
Outputs	PNP	NPN

INPUTS 

OUTPUTS 

INPUTS 

OUTPUTS 

**Example of specific configuration**

Inputs/Outputs setting for connecting **C1 Version** to the tool connector of the Universal Robots UR3/UR5/UR10/CB3 Series:

- Inputs: NPN
- Outputs: PNP

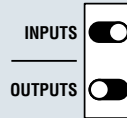

**VI. SUPPLY AND PNEUMATIC CONNECTION OF VACUUM GRIPPERS**

**VI.1 Pneumatic supply characteristics**

- Supply: non-lubricated air, 5 microns filtered, according to ISO 8573-1:2010 [4:5:4].
- Operating pressure: from 5 to 6 bar
- Optimal pressure:
  - CVGC150x150: 5.5 bar
  - CVGC240x120: 6 bar
  - CVGC 320x160: 6.4 bar

	Air consumed	Air drawn in	Max. vacuum (%)	Sound level (dBA)
<b>CVGC150X150</b>	135 NI/min (4.77 SCFM)	90 NI/min (3.18 SCFM)	85	72
<b>CVGC240X120</b>	270 NI/min (9.53 SCFM)	180 NI/min (6.36 SCFM)	85	71
<b>CVGC320X160</b>	345 NI/min (12.2 SCFM)	210 NI/min (7.42 SCFM)	85	66

**VI.2 Connection**

Connect the compressed air to the push-in connector  $\varnothing$  8 mm.

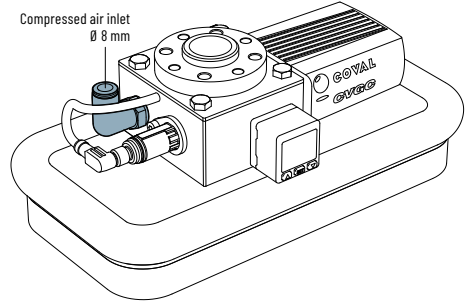

**VII. ASSEMBLY INSTRUCTIONS**

**VII.1 Assembly instructions for CVGC**

A31	C1
A50	C2
	C3
	C4
	C5

Note: - M5 indexing pin provided for A31 mounting interface  
- M6 indexing pin provided for A50 mounting interface

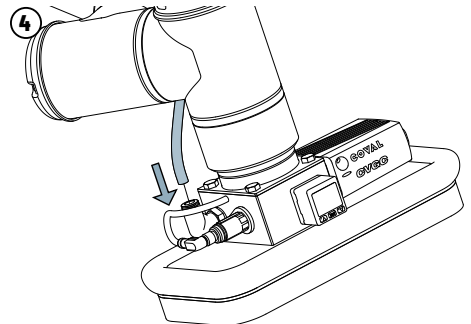
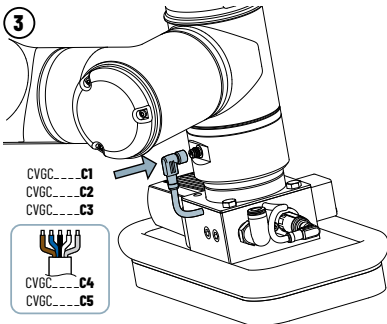
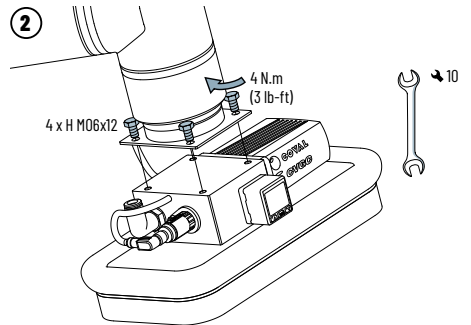
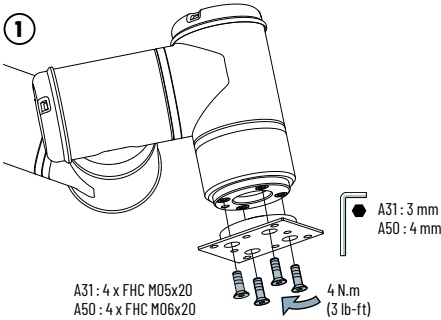

**VII.2 Assembly instructions for CVGC**

<b>A63</b>	<b>C4</b>
	<b>C5</b>
	<b>C6</b>

Note: - M6 indexing pin provided for A63 mounting interface

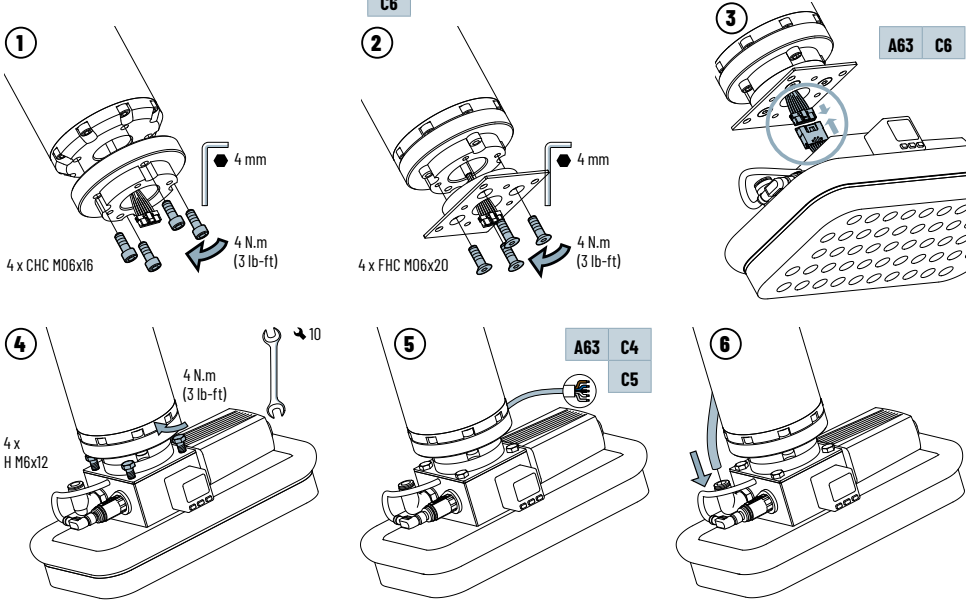

For the use of CVGC series carbon vacuum gripper on UNIVERSAL ROBOTS e-Series robots, a URcap plugin with installation and programming instructions are available for download on the COVAL website: <https://doc.coval.com/CVGC>

**VIII. GENERAL CHARACTERISTICS**

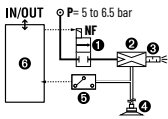

- ❶ "Vacuum" solenoid valve
- ❷ Venturi
- ❸ Through-type silencer
- ❹ Foam gripping interface
- ❺ Electronic vacuum switch
- ❻ Input / Output board

- Supply: non-lubricated air, 5 microns filtered, according to ISO 8573-1:2010 [4:5:4].
- Operating pressure: from 5 to 6.5 bar
- Optimal pressure:
  - CVGC150x150: 5.5 bar
  - CVGC240x120: 6 bar
  - CVGC 320x160: 6.4 bar
- Maximum vacuum: 85%.
- Vacuum command light: orange LED
- Electric protection grade: IP40
- Control voltage: 24 V DC +/-10%

- Vacuum control: 24 V DC PNP/NPN
- Power consumption: 65 mA (no load)
- The switching type of the inputs / outputs is configurable to PNP or NPN
- Outputs:
  - 1 x "Vacuum level" signal analogic 1 to 5 V DC (depending on robot model, see "Electrical Connections" section)
  - 1 x "Gripped product" switching output 24 V DC PNP/NPN NO or NC (125 mA max.)
- Service life: 30 million cycles
- Operating temperature: from 0 to 50° C.
- Materials:
  - Gripper: carbon, PA 6.6 15% FG, brass, stainless steel, PETP.
  - Valve: aluminum, steel, NBR.
  - Foam gripping interface: EPDM.
- Noise level:
  - CVGC 150x150: 72 dBA
  - CVGC 240x120: 71 dBA
  - CVGC 320x160: 66 dBA

The values represent the average characteristics of our products.



**IX. USE AND APPLICATION**

**Max. capacity**

	Capacity <sup>(1)</sup> (kg)	 <sup>(2)</sup> (kg)
<b>CVGC 150X150</b>	<b>30</b>	<b>0.80</b>
<b>CVGC 240X120</b>	<b>38</b>	<b>1.0</b>
<b>CVGC 320X160</b>	<b>68</b>	<b>1.3</b>

(1) Indicative force for a vacuum gripper with foam interface covered 100% by the load, including a safety factor of 2 for horizontal handling and rigid, airtight surface.

(2) Weight indicated for a gripper with A31 or A50 mounting. For a gripper with A63 mounting, add 136 g.

**Foam Interface**

- Operating temperature: from -40 to 180° C (from -40 to 356° F)
- Avoid prominent shapes
- Caution: angle of approach.

**X. MAINTENANCE**

**X.1 Frequency**

Determination of the maintenance frequency according to the rates, the environment and the type of load.

→ **To be defined by the user.**

**Spare parts** (Order code according to CVGC model)

Ref.	Designation	CVGC150x150...	CVGC240x120	CVGC320x160
1	Foam protection	80005438	80005439	80005440
2	Foam gripping interface	80005296	80005297	80005298

**X.2 Procedure for replacing the gripping foam**

1. Manually remove the used FOAM interface.
2. Clean the carbon plate with a chemical degreaser (e.g. NECTRAL) to remove unwanted compounds (adhesive residue, grease...).

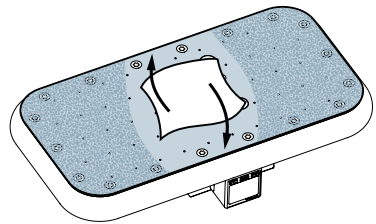
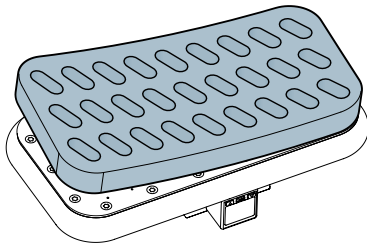

**Recommendation**

- Cover 100% of the surface of the foam gripper interface.
- Position of the gripper:
  - Always position the gripper in the centre of the load to manipulate.
  - CVGC vacuum grippers are designed for the handling of loads in horizontal movement.
- It is not recommended to use the CVGC for vertical gripping as the foam could deteriorate quickly.
  - In the rare case of vertical use, tests should be performed prior to commercial use
  - COVAL will not be held responsible for the premature degradation of the foam.

Note: For applications with high accelerations, or a grip in vertical position, the safety factor must be calculated according to application-specific conditions.

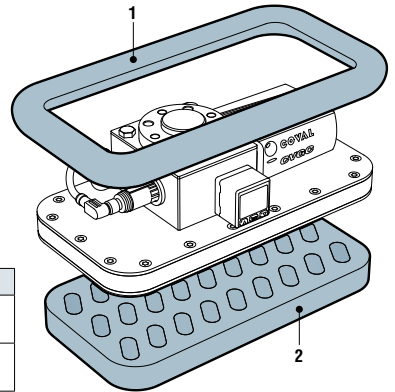

- On the replacement foam, rub the protective film on the adhesive side for a few seconds to activate the cells and promote bonding.

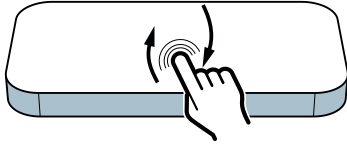

- Remove the protective film.

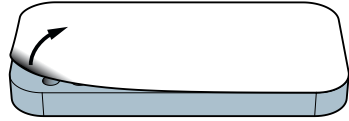

- Adhere foam to carbon plate by aligning the holes.

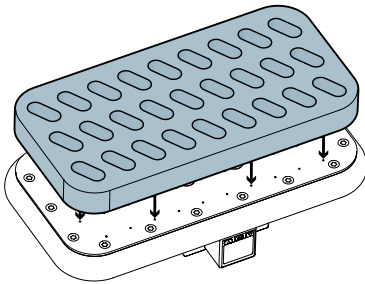

- Turn the gripper over and place it on a flat, smooth and clean surface. Press lightly on the box for 30 seconds so that the foam is uniformly glued to the carbon plate.

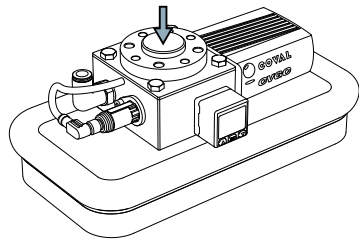

To check proper functioning of the vacuum gripper, complete airtight leak test (see chapter XI).

## XI. VACUUM GRIPPER AIRTIGHT LEAK TEST

To ensure the proper functioning of the CVGC vacuum grippers after a maintenance operation, it is important to complete an airtight leak test:

- Place the gripper on a clean, smooth, flat and waterproof surface.
- Activate vacuum.
- Check the vacuum level on the electronic vacuum switch. It must be at least 80% (-800 mbar) at the optimal functioning pressure of the housing.

If the vacuum level is not reached, check:

- the quality of the test surface,
- the wear of the gripping foam and its adhesive
- the size of the compressed air hose (internal Ø 6 mm minimum),
- the quality of the compressed air network (connections, pipes, leaks or damage) and replace defective components.
- the pressure of the compressed air network:
  - Optimal functioning pressure:
  - CVGC150x150: 5.5 bar
  - CVGC240x120: 6 bar
  - CVGC 320x160: 6.4 bar

**XII. RELATED DOCUMENTS TO BE DOWNLOADED**

- Vacuum switch manual PSD100CPNP: <https://doc.coval.com/PSD>
- Installation and operating instructions for the URCap plugin: <https://doc.coval.com/CVGC>



Retrouvez tous les documents en différentes langues sur le site coval : <https://doc.coval.com/CVGC>



Please find all the documents in different languages on the coval website: <https://doc.coval.com/CVGC>



Finden Sie alle Dokumente in verschiedenen Sprachen auf der COVAL-Homepage: <https://doc.coval.com/CVGC>



Tutti i documenti nelle differenti lingue sono presenti sul sito Coval: <https://doc.coval.com/CVGC>



Podrá encontrar todos los documentos en diferentes idiomas en la página web de coval: <https://doc.coval.com/CVGC>

#### A TECHNOLOGICAL PARTNER ON A GLOBAL SCALE

Located in the southeast region of France, COVAL conceives, manufactures and globally distributes high performance, advanced vacuum automation components and systems for industrial applications in all branches.

COVAL is an ISO 9001: V2015 certified company which offers innovative solutions integrating reliable and optimized components with intelligent functionalities. The focus is to provide the most personalized and economic solution to a given application while assuring a significant improvement in the productivity and the safety for the vacuum users around the world.

COVAL has an ambition for technical excellence and innovation. As a specialist in vacuum automation, COVAL is reputed for offering reliable, personalized, cost effective and productive solutions.

The references of COVAL can be found in several industrial sectors (Packaging, Automotive Industry, Plastic, Graphic, Aeronautic...) where vacuum handling is important for high efficiency and productivity.

COVAL markets its products and services all over Europe, in the United States and South America through its subsidiaries and authorized distribution network. COVAL strives to provide customer driven solutions and gives the best possible treatment to satisfy all its clients.

*For all enquiries from Australia, Africa and Asia kindly contact COVAL head office in France.*



**COVAL S.A.S.**

**(Head Office)**

Mail: [coval@coval.com](mailto:coval@coval.com)  
Phone: +33 (0)4 75 59 91 91  
[www.coval.com](http://www.coval.com)



**COVAL INC.**

Mail: [contact@coval-inc.com](mailto:contact@coval-inc.com)  
Phone: (919) 233 4855  
[www.coval-inc.com](http://www.coval-inc.com)



**COVAL IBERICA**

Mail: [contacto@coval.com](mailto:contacto@coval.com)  
Phone: (+34) 930 185 441  
[www.coval-iberica.com](http://www.coval-iberica.com)



**COVAL GERMANY**

Mail: [kontakt@coval.com](mailto:kontakt@coval.com)  
Phone: +49 (0)7121 7999-250  
[www.coval-germany.com](http://www.coval-germany.com)



**COVAL ITALIA**

Mail: [coval.it@coval.com](mailto:coval.it@coval.com)  
Phone: +39 011 958 8660  
[www.coval-italia.com](http://www.coval-italia.com)



**COVAL CHINA**

Mail: [sales@coval.net.cn](mailto:sales@coval.net.cn)  
Phone: +86 21 64295600  
[www.coval.net.cn](http://www.coval.net.cn)