

GVP

Vacuum Pumps

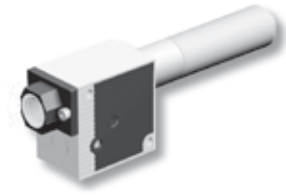

The GVP series vacuum pumps are the simplest in the range. They exist in 5 levels of power (suction rate) and 3 different levels of maximum vacuum:

- Version X (50% vacuum for very porous products).
- Version T (75% vacuum for porous products).
- Version N (85% vacuum for air-tight products).

For the same nozzle diameter, the suction flow rate increases proportionally to the decrease in the maximum vacuum level.

In addition to suction pads, they can also be used for dosing liquid, spraying and tank depressurization.

Industry-specific applications

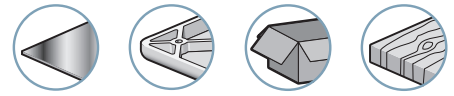

Characteristics

Model	Ø Nozzle (mm)	Air consumed (NI/min)	Max. vacuum (%)			Air drawn in (NI/min)			At air pressure (bar)
			X	T	N	X	T	N	
GVP 12	1.2	67	40	75	85	150	63	45	4
GVP 15	1.5	100	50	75	85	180	95	70	4
GVP 20	2	180	50	75	85	250	160	125	4
GVP 25	2.5	270	50	75	85	360	240	200	4
GVP 30	3	400	50	75	85	450	330	265	4

As standard, versions N and T are delivered with silencer S and version X with silencer K. Only exception, the GVP 30 is fitted with silencer K.

Advantages

- Adaptable to all industries
- Optimized performance for handling all types of objects
- Options
- Light and compact
- Silent operation
- No clogging thanks to the through type silencer

7
GVP

Evacuation Time in Seconds per Liter

% vacuum versions	10 %			20 %			30 %			40 %			50 %			60 %			70 %			80 %			85 %		
	X	T	N	X	T	N	X	T	N	X	T	N	X	T	N	X	T	N	X	T	N	X	T	N	X	T	N
GVP12	0.05	0.10	0.14	0.11	0.22	0.30	0.22	0.37	0.49	0.62	0.55	0.71	-	0.78	0.97	-	1.16	1.33	-	1.92	1.81	-	-	2.66	-	-	3.42
GVP15	0.04	0.07	0.09	0.09	0.15	0.20	0.15	0.24	0.32	0.27	0.36	0.46	-	0.52	0.63	-	0.77	0.85	-	1.27	1.16	-	-	1.71	-	-	2.20
GVP20	0.03	0.04	0.06	0.06	0.09	0.12	0.11	0.14	0.19	0.19	0.22	0.28	-	0.31	0.38	-	0.46	0.52	-	0.76	0.71	-	-	1.04	-	-	2.13
GVP25	0.02	0.03	0.03	0.04	0.06	0.07	0.08	0.10	0.11	0.14	0.14	0.16	-	0.21	0.22	-	0.30	0.30	-	0.50	0.41	-	-	0.60	-	-	0.77
GVP30	0.01	0.02	0.02	0.03	0.04	0.05	0.06	0.07	0.08	0.11	0.10	0.12	-	0.15	0.17	-	0.22	0.23	-	0.37	0.31	-	-	0.45	-	-	0.58

Specifications

Supply	Non-lubricated filtered air, pressure 2 to 6 bar
Optimum pressure	4 bar
Weight	100 to 265g
Material	POM - 2017A - Cu Zn
Temperature	0 to 80 °C

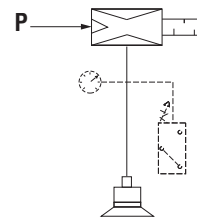

For all orders, please specify:
Model + Nozzle Ø + % vacuum + Silencer + C.A. fitting
 e.g.: GVP30NK14

1: Model	2: Nozzle diameter	3: % vacuum	4: Silencer	5: C.A. fitting		
GVP	12	1.2 mm	X	50 % vacuum	14	G1/4" Female
	15	1.5 mm	T	75 % vacuum		
	20	2 mm	N	85 % vacuum		
	25	2.5 mm				
	30	3 mm				

(1) no silencer for nozzle Ø 30.

GVP

Vacuum Pumps

Dimensions



Dimensions

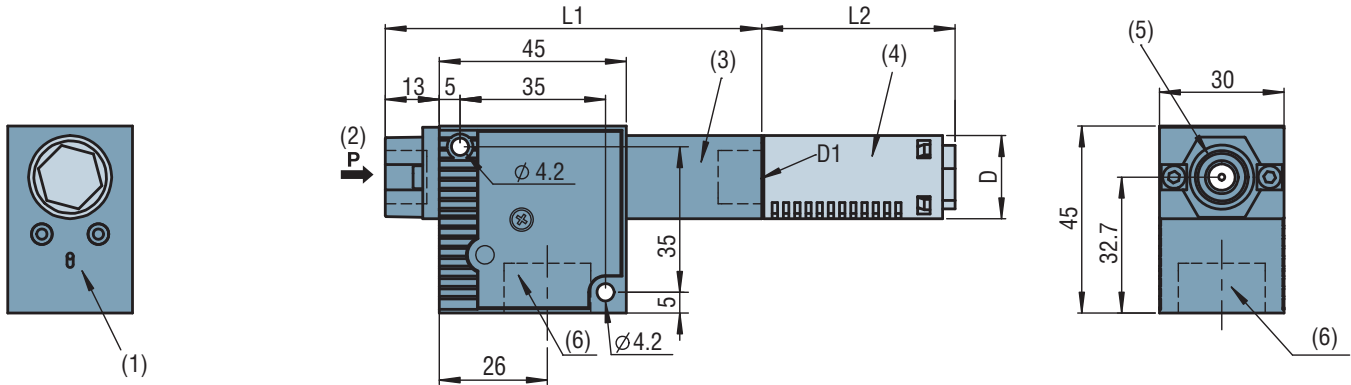

Models	L1		L2			D		D1	
	X	N/T	S(N/T)	K(N/T)	K(X)	X	N/T	X	N/T
GVP12	76	81	46	68	121	30	20	G1/2"-F	G1/4"-F
GVP15	76	91	46	68	121	30	20	G1/2"-F	G1/4"-F
GVP20	76	76	62	121	121	30	30	G1/2"-F	G1/2"-F
GVP25	76	76	62	121	121	30	30	G1/2"-F	G1/2"-F
GVP30	148	148	-	121	121	30	30	G 1/2 "-F	G1/2"-F

- (1) Vacuum switch option mounting zone
- (2) 4 bar compressed air supply
- (3) Exhaust
- (4) Silencer model S or K
- (5) G1/4"-F
- (6) Vacuum G1/2"-F

Options
 ■ Vacuum switches see pages 7/5 and 7/6.
 ■ Other options see pages 7/6 and 7/7.
 ■ Silencer see page 11/11.

Curves
 See page 7/4.

Note: all dimensions are in mm

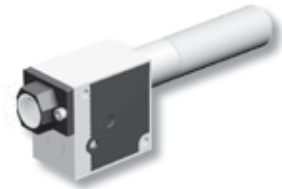

Vacuum Generated - Supply pressure 4 bar

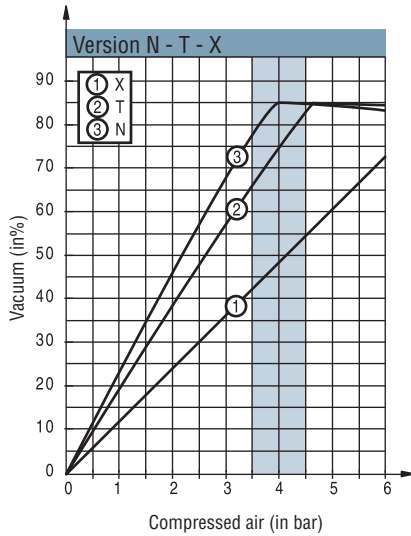

Air Consumed - Supply pressure 4 bar

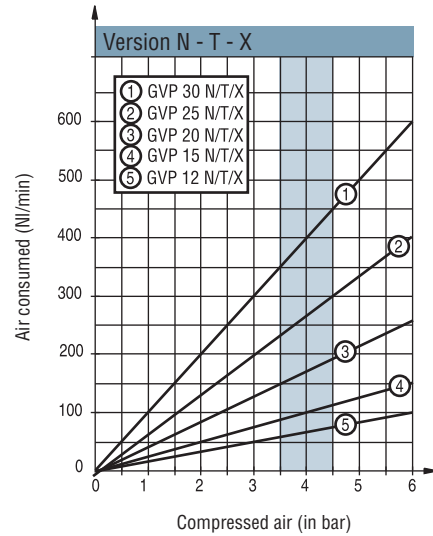

Suction Flow Rate/Vacuum Curves - Supply pressure 4 bar

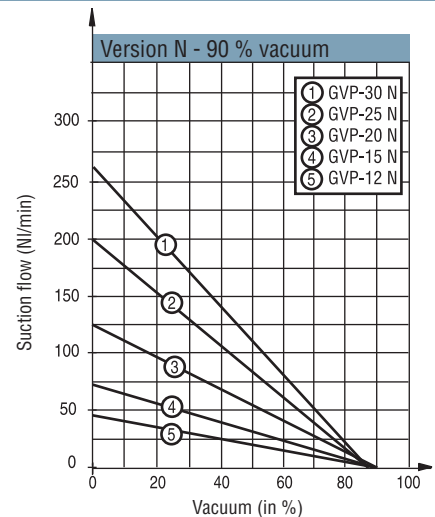
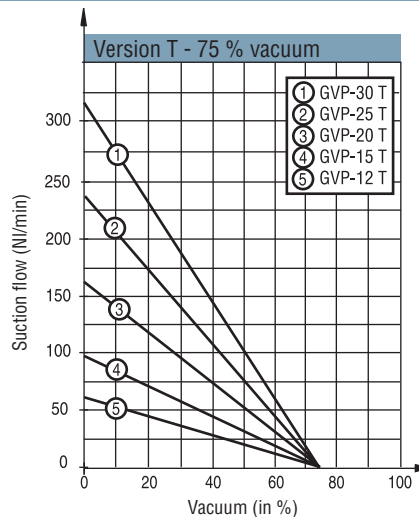
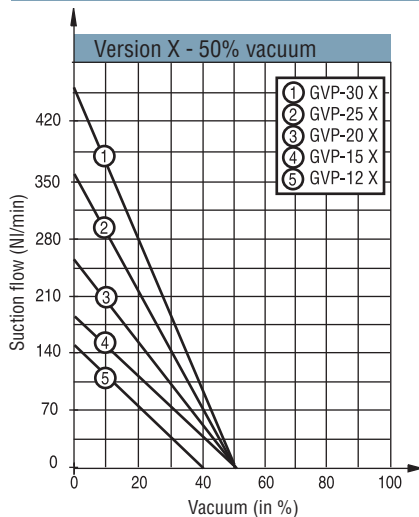

Suction Flow Rate Generated - Supply pressure 4 bar

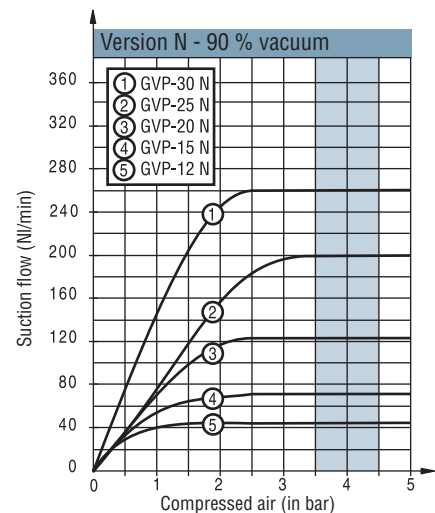
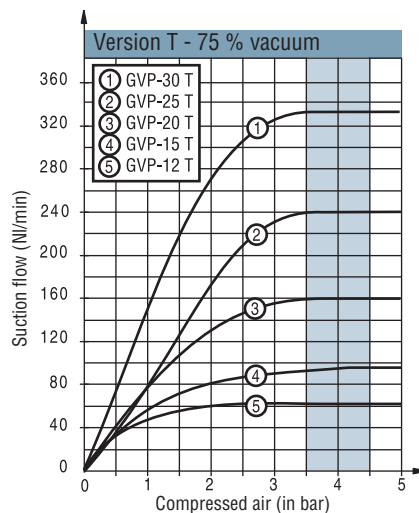
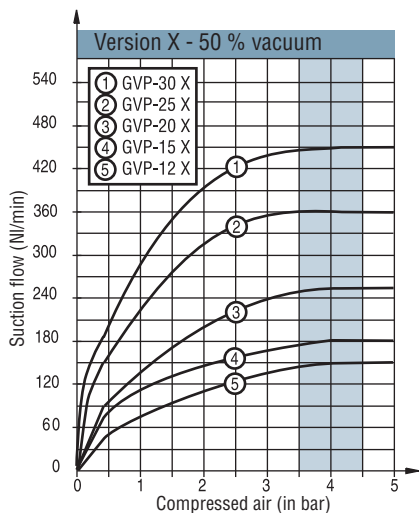

GVP 7

Customer-mounted Vacuum Pump Options

Electronic Vacuum Switch with Display

GVO PSA 100 C option

(See exact characteristics page 12/4)

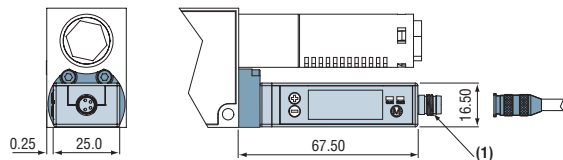

Delivered with M8 cable (2 meters)

(1) M8 connector

Our top-of-the-range electronic vacuum switch, the PSA 100C has an LED display showing the vacuum value in different units. It also has two separate outputs with independently regulated hysteresis, NO or NC

- PNP as standard
- M8 connector.
- Connection cable, see page 11/12.

Electronic Vacuum Switch

GVO PSP 100 C (M5), PSP 100 L (M5) option

(See characteristics page 12/7)

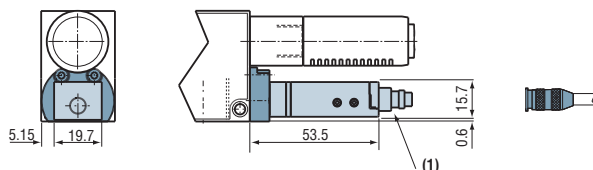

Delivered with M8 cable (2 meters)

(1) M8 4 pole connector

The vacuum data collected is always very reliable even with a large number of suction pads, thanks to the precision of the PSP 100. It has one output with hysteresis adjustment.

- PNP as standard
- M8 connector.
- Connection cable, see page 11/12.

Vacuum Switch with Electrical Signal

GVO PSE 100 E or EC option

(See characteristics page 12/9)

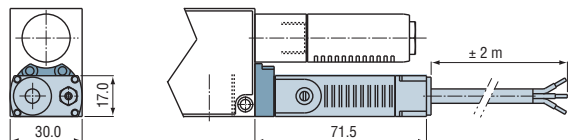

GVO PSE 100 E with cable (length 2 metres)

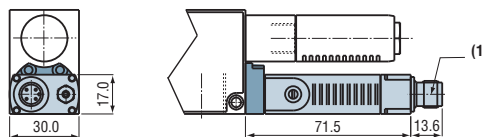

GVO PSE 100 EC with M12 connector (delivered without connection cable)

(1) M12 male connector

The PSE 100 E or EC vacuum switch indicates the level of vacuum in the suction pad circuit. For a small number of suction pads (5 to 10 maximum). This indication is enough to prove an object is gripped. Hysteresis (125mbar) must also be taken into account according to the use of the vacuum switch data.

Check that the vacuum pump supply pressure generates a level of pressure equal to the threshold setting.

For connection cable, see page 11/12.

Customer-mounted Vacuum Pump Options

Vacuum Switch with Pneumatic Signal

GVO PSE 100 P NO or NC option (see characteristics page 12/10)

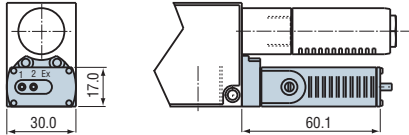

For use in fully pneumatic applications or explosive environments. The vacuum switch enables a pressure data message to be given when a vacuum threshold is reached.

Vacuum Gauge

GVO VAF 111 40 option (See characteristics page 12/12)

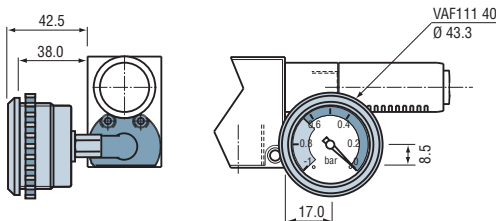

The vacuum gauge displays the level of vacuum in the suction pad circuit. This option makes it simple to keep the status of the vacuum circuit under constant surveillance.

7 Plug to Shut off Vacuum Data

GVOB Option

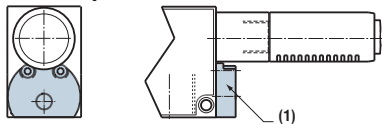

(1) Plug

This plug option makes it possible to shut off the vacuum signal to avoid affecting operation of the vacuum pump if a GVO option is removed.

Factory-mounted Vacuum Pump Options

GVO AL and GVO AL NPT option (for GVP vacuum pump)

Body and flange G1/4"-F Gas in aluminum (on request).

■ Note: It is no longer possible to mount vacuum gauge options.

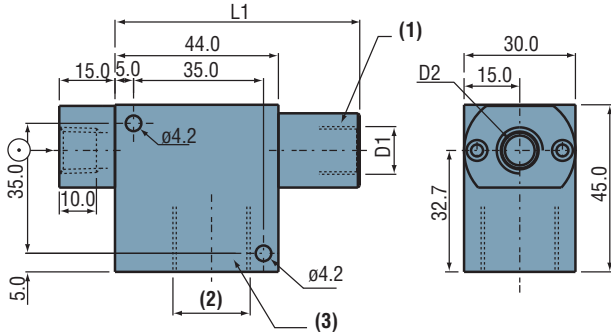

- | | | | |
|-------------|---------------------------------|------------|---------|
| L1 = | L1 GVP (plastic) - 1mm | (1) | Exhaust |
| D1 = | D1 (GVP N, T and X) | (2) | G1/2"-F |
| D2 = | G1/4"-F
1/4 NPT (on request) | (3) | Vacuum |

GVO P Option

With G1/2"-F protective extension.

The G1/2"-F extension is recommended for double valve models or with pneumatic vacuum switch to protect components during mounting or installation.

The extension is fitted with a 400 micron stainless steel filtration grid as standard.

