

COVAL

vacuum managers

LEMAX

Integrated Mini Vacuum Pumps with "ASC"



AIR Saving Control

ADVANCED VACUUM SOLUTIONS

Integrated Mini Vacuum Pumps with "ASC" (Air Saving Control)



Industry-specific applications

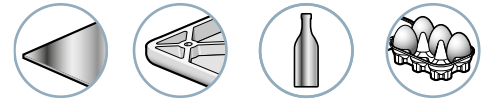

For all objects, airtight or not very porous

Advantages

- Energy savings of 75% to 99% (depending on application) thanks to automatic **ASC** (Air Saving Control) operation.
- "All-in-one" solution, no more peripherals to be added.
- Simplified installation and use thanks to the Plug & Play system.
- Unmatched compactness: installation close to suction cups → short response times and energy savings.
- No clogging, thanks to the through-type silencer.
- Controlled or timed blow-off.
- Gripping safety in the event of electricity shut-off.
- Smart communication → Easier experience at all stages: initial settings, production, maintenance.

Compact Integration

The illustrations below demonstrate the 9 functions integrated in the mini-module, and their respective roles in operation.

The result of this COVAL performance is:

- **A mini module** (≅ 130 g) that is easy to install close to the suction cups, reducing the volume to be evacuated → increased speed and energy savings.
- **A complete module**, therefore not requiring any additional function or connections.

The **LEMAX** compact modules integrate all the functions of "industrial vacuum" including simple, efficient, economical compressed air usage and are adapted for every application:

- 1 3.5 bar pressure regulator
- 2 Solenoid valve "vacuum"
- 3 3.5 bar optimized Venturi
- 4 Through-type silencer
- 5 Electronic vacuum switch
- 6 Integrated electronics
- 7 Solenoid valve "blow-off"
- 8 Blow-off flow adjustment
- 9 Check valve on vacuum

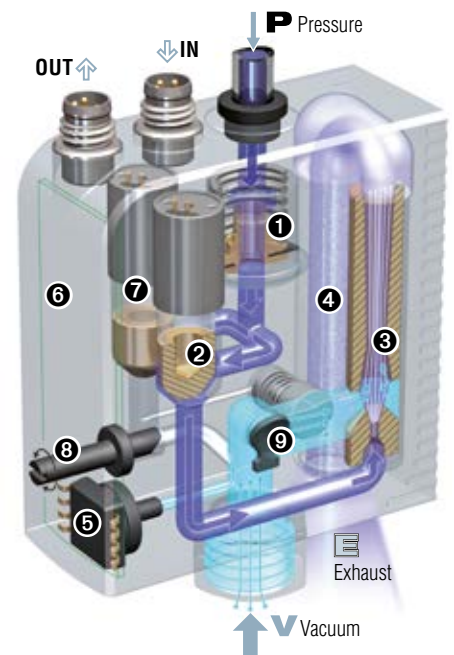
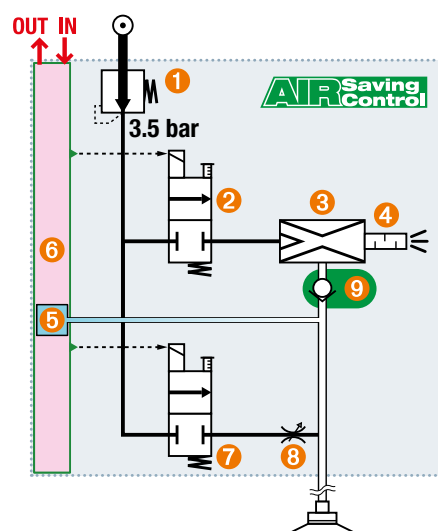

Schematic representation

Combination of non-return 9 and advanced electronics 6 ensures the **ASC's** automatic performance.

→ **Once desired vacuum level is reached, the LEMAX no longer consumes air when gripping the product.**



90% energy savings
(on average).

Smart Communication

The adjacent illustration presents the display panel which enables:

- Initial settings
- Any adjustments
- Production monitoring
- Maintenance

In particular, the no "**ASC**" alert, (see next page), helps to start maintenance operations in order to return to "**ASC**" operation, which is especially energy-saving.





"Air Saving Control" Cycle

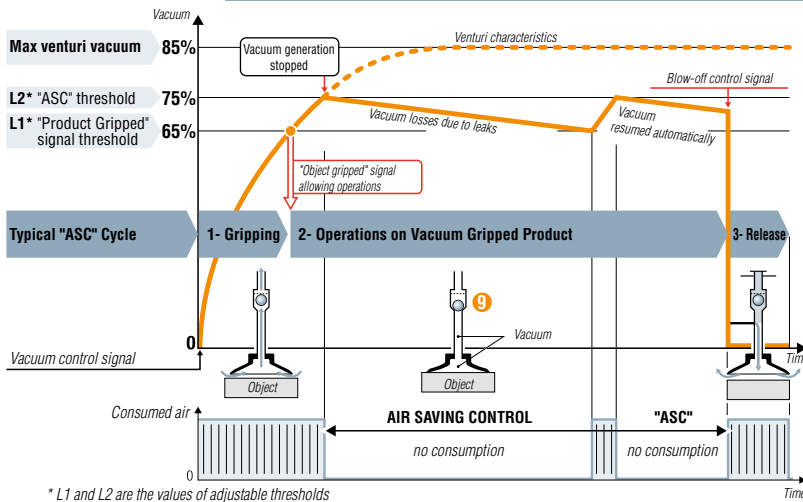

As illustrated above, the LEMAX module automatically executes the "ASC" cycle, thus saving the maximum amount of energy, based on the following 3 phases.

1- Gripping the object

The "vacuum" solenoid starts the cycle by supplying the venturi which generates the vacuum to quickly pick up the object with the suction cup → short-term consumption.

2- Operations on the object held by vacuum

The vacuum level is constantly monitored by the vacuum switch. When it reaches the L1 threshold (65%), the "gripped object" signal is generated, which allows the planned operations (transfer, machining, etc.). When the vacuum reaches threshold L2 (75%), the supply to the venturi via the solenoid valve is cut off → consumption is halted. The object remains held by the retained vacuum thanks to the closed valve. Micro-leaks will generally cause the vacuum level to fall slowly. Each time it falls below 65%, vacuum generation is briefly resumed until it reaches threshold L2 (75%).

3- Releasing the object

At the end of operations, blow-off is ordered. The "blow-off" solenoid valve generates a stream of air which closes the isolation valve, blows on the object to release it quickly.

Smart Adaptation

The illustration below shows the adaptation capacities of the LEMAX module. "ASC" operation is automatic for any object that is airtight enough (cycle 1). If a leak occurs (cycle 2), due to a rough object or to suction-cup wear, the module automatically detects the anomaly, ends the cycle without "ASC" in order to continue production and reports the event for possible maintenance. Production continues. Once everything is returned to normal (cycle 3), "ASC" operation is automatically resumed.

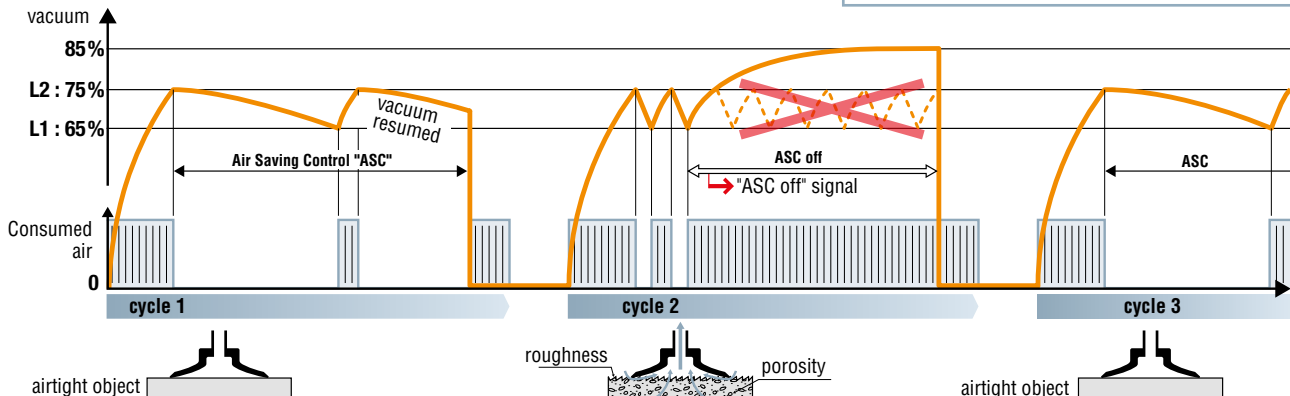

1- Gripping + Transfer (Ø 1.4 mm nozzle, 0.2 l of vacuum)

Phase	Duration	Air consumption		Energy savings achieved
		"ASC" off	"ASC" on	
Gripping	0.28 s	0.014 ft ³	0.014 ft ³	75 %
Transfer	1.20 s	0.063 ft ³	0	
Release	0.14 s	0.007 ft ³	0.007 ft ³	
		0.084 ft ³	0.021 ft ³	

2- Clamping + Operations (Ø 1.4 mm nozzle, 0.4 l of vacuum)

Phase	Duration	Air consumption		Energy savings achieved
		"ASC" off	"ASC" on	
Clamping	0.55 s	0.028 ft ³	0.028 ft ³	99 %
Operations	60 s	3.178 ft ³	0	
Release	0.14 s	0.007 ft ³	0.007 ft ³	
		3.213 ft ³	0.035 ft ³	

Resulting savings

Energy savings from "ASC" are major, as the two examples opposite above:

- 75% savings for transferring an object after gripping.
- 99% savings for holding an object during a 1 minute operation.

The investment generally pays for itself in just a few months.

"ASC": AN ADVANTAGE WITHOUT LIMITATIONS

Saving energy has become essential. With LEMAX, thanks to "ASC", energy is automatically saved without interfering with established operations:

1- No specific adjustment: The initial setting (L1 = 65%, L2 = 75%) is suitable for most applications.

2- Production regardless of what happens: Operation is always ensured, if necessary without "ASC", if the leakage level is too high.

3- Guided maintenance: Clear display of the need for maintenance to return to auto-regulated "ASC" operation.



The LEMAX vacuum pumps, which integrate an ASR "venturi regulator" combination, share values that COVAL values greatly: they greatly reduce the volume of compressed air consumption and noise level..



Power Determined by the Venturi Nozzle Diameter

The table shows the power levels generated by each of the nozzle diameters available: when the module is operating with "ASC" off, a larger nozzle draws and consumes more compressed air.

On the other hand, during "ASC" operation, a large nozzle quickly reaches the vacuum threshold generating power shut-off.

In conclusion:

- A large nozzle enables quicker gripping without consuming more during "ASC" operation.
- A small nozzle consumes less only when operating continues without "ASC".

Selecting the Nozzle Diameter

Ø nozzle	Venturi characteristics during "ASC off" operation.		"ASC" operation - gripping at 65% vacuum - vacuum shutoff at 75% Time for a volume of 1l		
	air drawn in (SCFM)	air consumed (SCFM)	grip time (s) (65% vacuum)	time (s) up to 75% vacuum	air consumed (ft³)
1.4 mm	2.47	3.18	0.99	1.38	0.077
1.2 mm	1.59	2.30	1.53	2.15	0.077
1.0 mm	1.02	1.55	2.38	3.33	0.077



Suction Flow Rate / Vacuum Curves

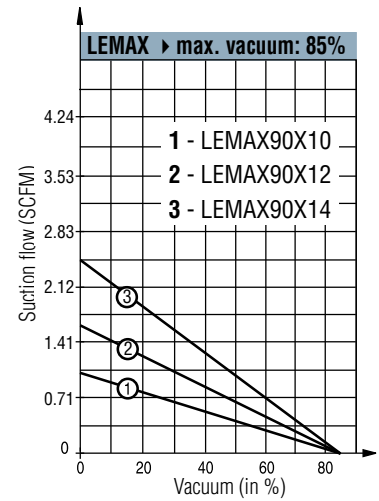

Select Vacuum Controlled by NC or NO Solenoid Valve

Vacuum controlled by a NC (Normally Closed) solenoid valve remains the simplest standard option to use. In the event of an electricity shutoff, the vacuum is interrupted and the object is released. On the contrary, with vacuum control by NO (Normally Open) solenoid valve, the vacuum continues to be generated in the event of an electrical shutoff: positive object-holding security.

The diagrams opposite show that both versions are controlled by the same "vacuum" signal ν :

- NC version, the signal ν controls the vacuum generation.
- NO version, the signal ν controls the vacuum shutdown.

Note, however, that the NO version requires blow-off controlled by a specific signal: automatic, timed blow-off can only be configured in the NC version.

NC solenoid valve

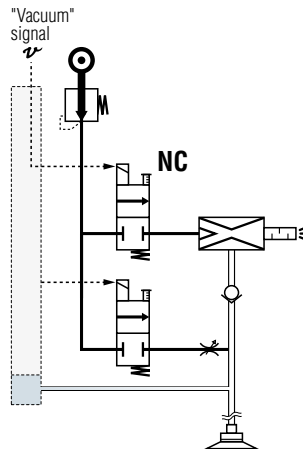

NO solenoid valve

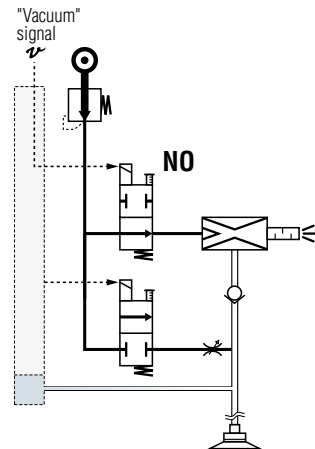

Stand-alone or Island Modules?

Stand-alone modules are suitable for the most common applications: one module controls one or more suction cups which all operate according to the same sequence.

When several suction cups are operating according to different sequences, multiple modules are required, which can be:

- several autonomous modules;
- a group of these modules with an internal common pressure unit.

The illustrations opposite guide the selection:

- stand-alone modules are coupled with integrated pressure regulators (ASR)
- in an island, the integrated regulator is removed: to maintain the advantage of economical and silent operation, it is recommended to reduce the island's common pressure supply pressure to 4 bar.

Network pressure:
4.5 to 7 bar

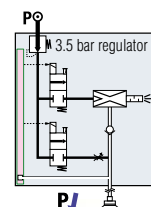

common pressure unit (4 bar)

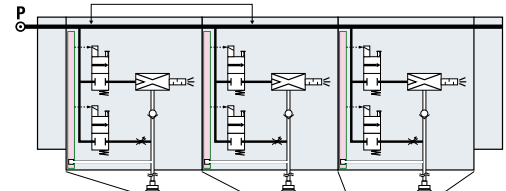

stand-alone module

P optimal = 4 bar
(operation at 4-7 bar)

island of 3 modules
supplying suction cups
according to different
sequences





Part numbers for an island assembly or components in an island

Part numbers for stand-alone units

LEM **MAX** **90** **X** **14** **S** - - **B3**

VACUUM LEVEL

maximum 85%
vacuum optimum for
airtight objects **90**

NOZZLE DIAMETER

Ø 1.4 mm nozzle	14
Ø 1.2 mm nozzle	12
Ø 1 mm nozzle	10

COMPOSITION OF THE MODULE

Vacuum pump controlled by a Normally Closed (NC) solenoid valve

LEM90X...S...

- In the event of an electrical shut-off, vacuum is no longer generated.
- Optional configured blow-off:
 - by specific signal,
 - automatic, timed 0 to 9.9 sec. (→ a single control signal vacuum and blow-off).

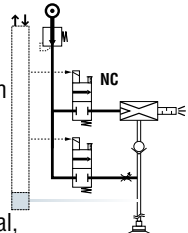

Vacuum pump controlled by a Normally Open (NO) solenoid valve

LEM90X...V...

- In the event of an electrical shut-off, the vacuum continues to be generated: gripped object held → positive security.
- Blow-off controlled by a specific signal.

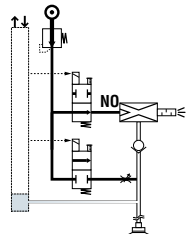

CONNECTORS

- Vacuum Pump with 2 M8 4-pin Connectors LEM90X...



- Discrete I/O.
- "Gripped product" switching output 24V DC / NO.
- 1 configurable auxiliary output:
 - either "Vacuum level" signal analogic 1 to 5V DC.
 - or "Without ASC" signal +5V DC switching output NO.

C14 Vacuum Pump with 1 M8 4-pin Connector LEM90X...**SC14** (S version only)



- "Gripped product" switching output 24V DC / NO.
- Automatic blow-off, timed 0 to 9.9 sec.

EXHAUST

Open (integrated silencer)	-
Exhaust manifold (G1/8"-F)	E

ISLAND ASSEMBLIES

B2 LEM90X...**B2** island assembly with 2 identical modules.



B3 LEM90X...**B3** island assembly with 3 identical modules.



B4 ...

If the planned island contains different module types, it must be ordered as separate components in order to then be assembled on site according to the arrangement suitable to the application.

COMPONENTS FOR THE ISLAND TO BE ASSEMBLED

B LEMAX...**B** Module that can be grouped (complete with integrated grouping screw).



Set of ends for a complete island, with grouping screw and common pressure unit plug.



PART NO.: LEMSETA

Input/Output switching type can be set to PNP/NPN

REFERENCE EXAMPLE COMPOSED OF A STAND-ALONE MODULE:

- **LEM90X14S** LEMAX, mini vacuum pump, 85% max. vacuum, 1.4 mm nozzle, controlled by a NC (Normally Closed) solenoid valve.

EXAMPLE COMPOSITE PART NUMBER FOR AN ISLAND ASSEMBLY:

- **LEM90X14SB3** LEMAX group assembly, containing 3 x 85% max. vacuum modules, Ø 1.4 mm nozzle, controlled by NC (Normally Closed) solenoid valve.

ORDER EXAMPLE FOR AN ISLAND TO BE ASSEMBLED:

- **LEM90X14VB**
 - **LEM90X12SB**
 - **LEM90X10VB**
 - **LEMSETA** → Set of ends for island.
- 3 LEMAX modules for an island, of different types.

Integrated Mini Vacuum Pumps with "ASC"

Dimensions, Mounting Options



Exhaust manifold: option E

The LEMAX mini vacuum pumps can be equipped with the "exhaust manifold" option, which provides a G1/8"-F connection to the exhaust in order to add a silencer, transfer the exhaust outside the work area or to avoid air discharge near the workpiece (LEMAX__E version).

This option must be specified at time of ordering as it cannot be added later.

Note: The design of the exhaust manifold and vacuum pumps do not guarantee the complete sealing of the exhaust and therefore cannot be used in a "clean room" environment.

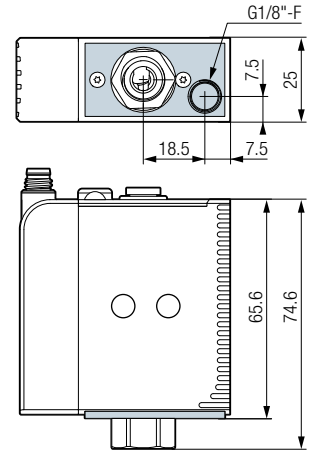

Stand-alone Modules



Side mounting

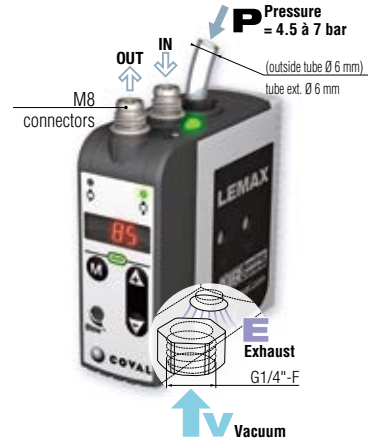
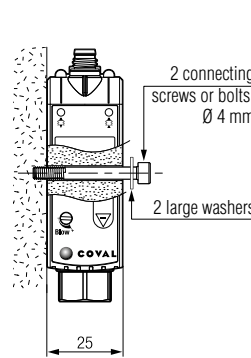
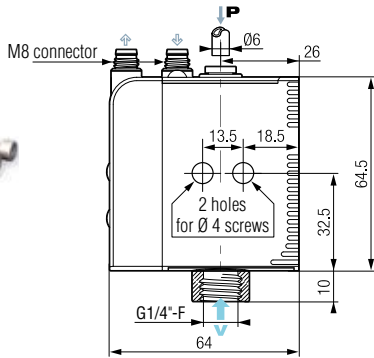

Front mounting

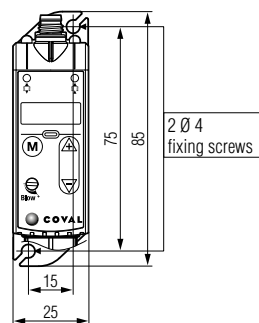
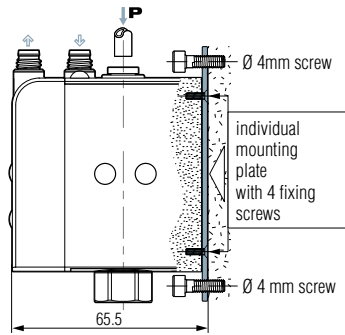

For front mounting, order the necessary kit, in addition to the module:

Front mounting kit:
1 plate + 4 screws

Part No.: LEMFIXA



Mounting on DIN rail

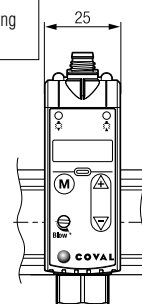
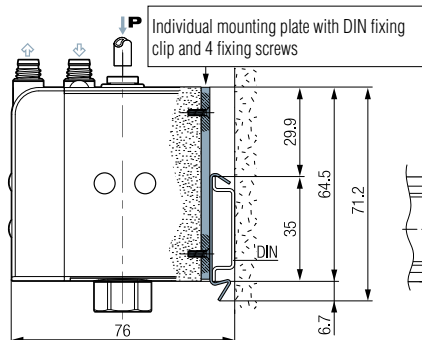

A module can be clipped onto a DIN rail. For this purpose, the module must first be equipped with an individual DIN installation plate, ordered separately:

DIN rail mounting kit:
1 plate/clip + 4 screws

Part No.: LEMFIXB



Islands

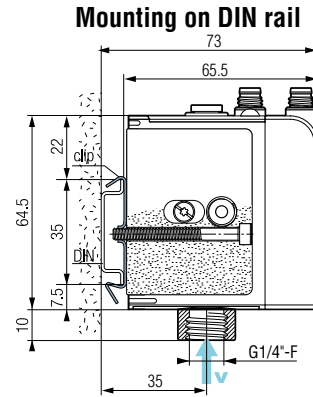
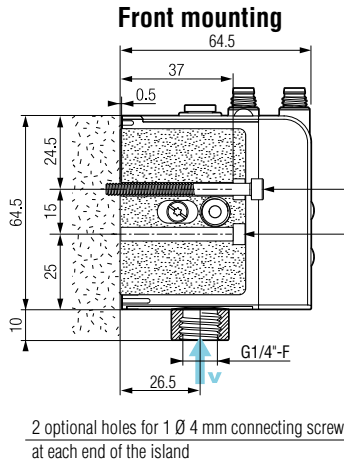
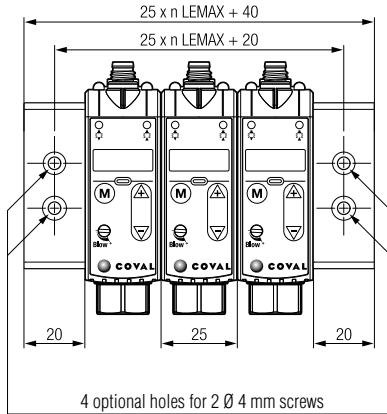

DIN rail mounting kit: 2 clips + 2 screws

Part No.: LEMFIXC

Assembling and Connecting an Island

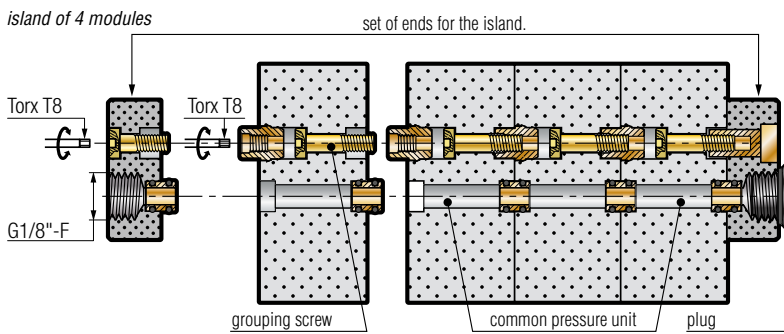

island of 3 modules



Maximum number of modules in an island:

- Ø 1.4 mm nozzle → 5 modules
- Ø 1.2 mm nozzle → 7 modules
- Ø 1 mm nozzle → 9 modules

Note:

In a single island, it is possible to combine LEMAX series modules and LEM series modules.



For NC Vacuum Pumps with 2 M8 4-pin connectors, model LEMAX90X..S..

configurable auxiliary output

- "vacuum level" signal analog, 1 to 5 VDC
- OR (configuration)
- ASC off signal +5 V TOR in NO

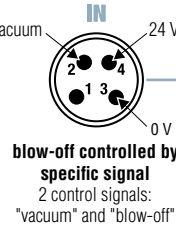
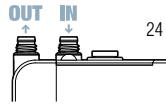
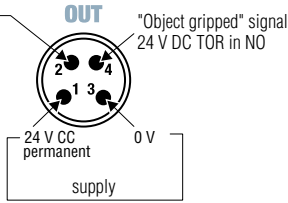

OR (setting)

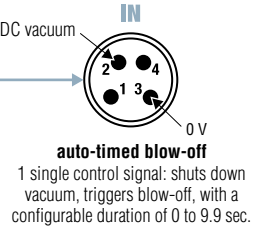

For NO Vacuum Pumps with 2 M8 4-pin connectors, model LEMAX90X..V..

configurable auxiliary output

- "vacuum level" signal analog, 1 to 5 VDC
- OR (configuration)
- ASC off signal +5 V TOR in NO

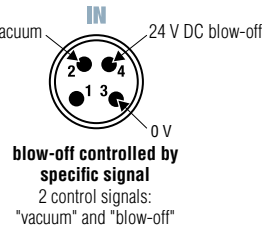
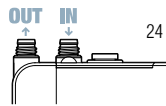
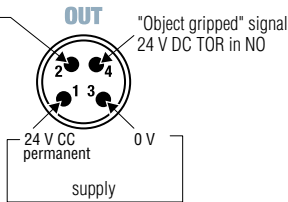

For NC Vacuum Pumps with 1 M8 4-pin connector, model LEMAX90X..SC14

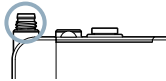
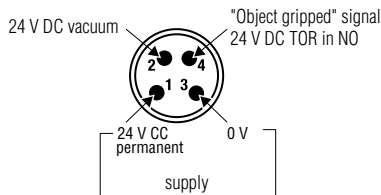

Accessories



Power supply cable M8, straight, female, 4-pin – open end:

- **CDM8**: length. 2 m.
- **CDM8N**: length. 0.5 m.

Power supply cable M8, elbow, female, 4-pin – open end:

- **CCM8**: length. 2 m.

Accessory

Protection for standalone mini-vacuum pumps LEMAX__SC14
(with one M8 connector), Part No.: 80004409

The COVER is made of silicone and serves as a protective sleeve for vacuum pumps, protecting them against splashing water, in particular during cleaning cycles.

- High level of protection against splashing water
- Easy to mount and clean





Overall Characteristics

- Supply: non-lubricated air filtered to 5 microns according to standard ISO 8573-1:2010 [4:5:4].
- Operating pressure: 4.5 to 7 bar.
- Mini dynamic pressure:
 - stand-alone version: P = 4.5 bar.
 - island version: P = 4 bar.
- Blow-off: adjustable flow:
 - stand-alone version: P = 3.5 bar.
 - island version: P network
- Maximum vacuum: 85%
- Suction rate: 1.02 to 2.47 SCFM.
- Air consumption: 1.55 to 3.18 SCFM during "ASC" off operation
- Integrated clog-free silencer.
- Noise level: approximately 68 dBA "ASC" off. 0 dBA with "ASC".
- Electrical protection level: IP 65.
- Max. operating frequency: 4 Hz.
- Endurance: 30 million cycles.
- Weight: 130 g.
- Operating temperature: 32 to 122 °F.
- Materials: PA 6-6 15%FV, brass, aluminum, NBR.

Electrical controls

- Control voltage: 24 V DC (regulated $\pm 10\%$), PNP or NPN.
- Current draw: 30 mA (0.7 W) vacuum or blow-off.

Integrated electronics

- Power supply 24 V; current draw: <57mA.
- Measuring range: 0 to 99% vacuum.
- Measuring precision: $\pm 1.5\%$ of the range, compensated in temperature.
- Display: 3 digits, 7 segments.

Service Characteristics

"Object gripped" output signal

- 24 VDC, switching output / NO, switching power: 125 mA PNP or NPN.

Configurable auxiliary output, choose either of the following (not available for version LEMAX90X_**SC14**):

- "vacuum level" signal, analog 1 to 5 V DC of the measuring range.
- "ASC" off signal, +5 V switching output / NO.

Input/Output switching type

- can be set to PNP (by default) or NPN.

Displays

- Scrolling display: 3 digits, 7 segments.
- Flashing if "ASC" off for maintenance.
- Status indicators: "Vacuum," green LED, "blow-off," red LED.
- "Object gripped" indicator: Green LED on front panel.

Configurations

- By mechanical keys and drop-down menu.
- Measurement unit selection (% , mbar, inHg).
- Choice of blow-off type:
 - LEMAX90X_**S**_ version: controlled by a specific signal or automatic and adjustable from 0 to 9.9 s.
 - LEMAX90X_**V**_ version: controlled by a specific signal.
 - LEMAX90X_**SC14** version: automatic and adjustable from 0 to 9.9 s.

Settings

- Display of the number of cycles (vacuum cycle counter).
- If the application so requires, specific adjustment of thresholds and hysteresis different to original factory settings (L1=65% h1=10%, L2=75%, h2=10%).

Autoreactivity

- Constant monitoring of leakage rate: abandon or automatic return to "ASC" operation.



COVAL
vacuum managers

vacuum
components



A TECHNOLOGICAL PARTNER ON A GLOBAL SCALE

Located in the southeast region of France, COVAL conceives, manufactures and globally distributes high performance, advanced vacuum automation components and systems for industrial applications in all branches.

COVAL is an ISO 9001: V2015 certified company which offers innovative solutions integrating reliable and optimized components with intelligent functionalities. The focus is to provide the most personalized and economic solution to a given application while assuring a significant improvement in the productivity and the safety for the vacuum users around the world.

COVAL has an ambition for technical excellence and innovation. As a specialist in vacuum automation, COVAL is reputed for offering reliable, personalized, cost effective and productive solutions.

The references of COVAL can be found in several industrial sectors (Packaging, Automotive Industry, Plastic, Graphic, Aeronautic...) where vacuum handling is important for high efficiency and productivity.

COVAL markets its products and services all over Europe, in the United States and South America through its subsidiaries and authorized distribution network. COVAL strives to provide customer driven solutions and gives the best possible treatment to satisfy all its clients.

For all enquiries from Australia, Africa and Asia kindly contact COVAL head office in France.



COVAL S.A.S.
Head Office



COVAL INC.



COVAL IBERICA



COVAL GERMANY



COVAL ITALIA



COVAL CHINA

Distributed by:



ISO 9001
certified quality
management system

COVAL VACUUM TECHNOLOGY INC.
901 Jones Franklin Road
Suite 100
Raleigh, NC 27606
Phone : (919) 233-4855
Fax : (919) 233-4854

www.coval-inc.com