

# COVAL

vacuum managers

## LEMP

Mini Vacuum Pumps without control with "ASR"



**AIR**Saving  
Regulator

## ADVANCED VACUUM SOLUTIONS

# LEMP

## Mini Vacuum Pumps without control with ASR (Air Saving Regulator)



**ASR** Saving Regulator

Industry-specific applications

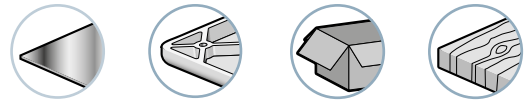

For all objects, porous or airtight

### Advantages

- Simplified installation and use thanks to the Plug & Play system
- Unmatched compactness: Installation close to suction cups  
→ short response times and energy savings.
- No clogging, thanks to the through-type silencer.
- A LEMP for every need: optional vacuum switch.
- Installation: standalone or island assembly.

### Compact Integration

The illustrations below demonstrate the functions integrated in the mini-module, and their respective roles in operation. The result of this COVAL innovation is:

- **A mini module** (≅ 110 g) that is easy to install close to the suction cups, reducing the volume to be evacuated → increased speed and energy savings.
- **A complete module** (including integrated pressure regulator and clog-free silencer), therefore not requiring any additional function or connection.

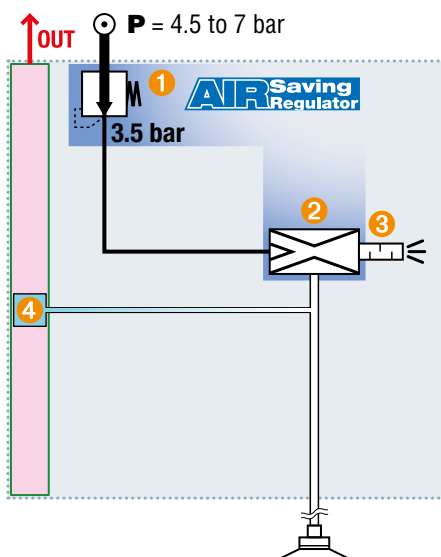

### Integrated functions

- 1 3.5 bar Pressure regulator
- 2 3.5 bar optimized Venturi
- 3 Clog-free silencer
- 4 Electronic vacuum switch

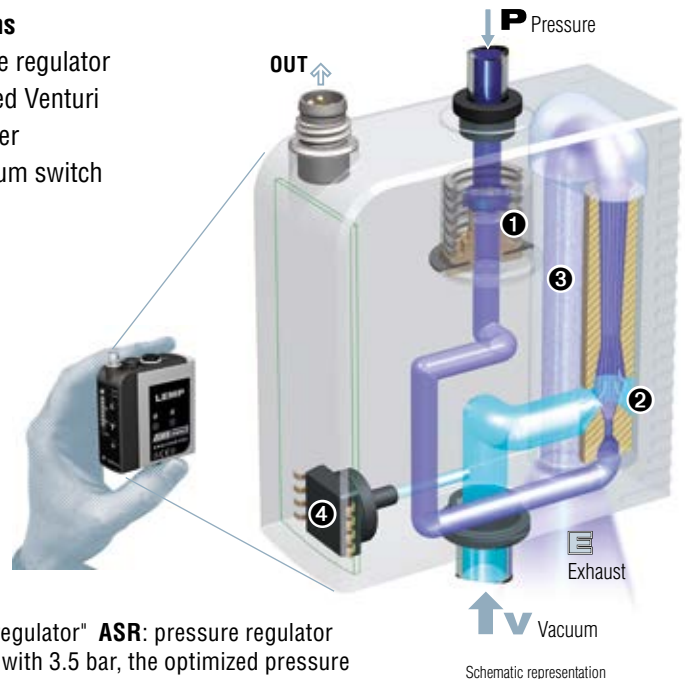

Combined "venturi regulator" ASR: pressure regulator 1 feeds venturi 2 with 3.5 bar, the optimized pressure for its operation.

→ **No more unnecessary consumption of compressed air.**

**ASR** Saving Regulator

**40%** Energy savings

### **ASR** (ASR): Air Saving Regulator

The LEMP vacuum pumps, which integrate an ASR "venturi regulator" combination, maintain ideals that COVAL values greatly: reducing both compressed air consumption and noise generation.

Regardless of pressure supplied by the compressed air network, the integrated regulator feeds the venturi at **3.5 bar** pressure, optimal for its operation.

- No more unnecessary energy consumption.
- No external regulator required and thus the risk of inadvertent misadjustment is eliminated.

Compared to pressures found in most compressed air networks (5-7 bar), the graph opposite demonstrates an achieved economy of 40% on average.

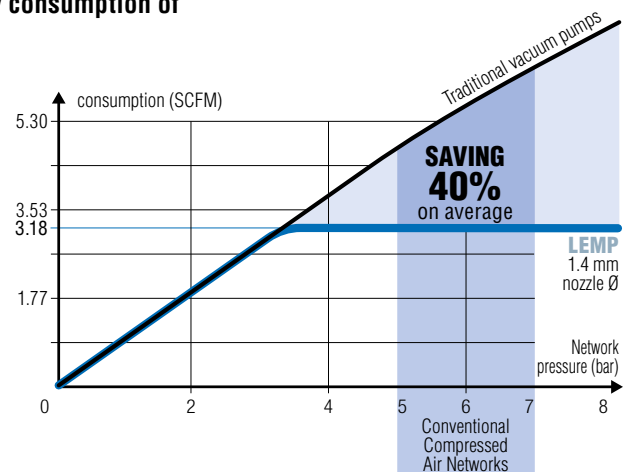



#### Version with Integrated Vacuum Switch

The front dialogue panel shown below displays the real-time vacuum level and lets the operator set the threshold level which triggers the "object gripped" signal allowing operations to continue.

This communications panel is particularly visual and intuitive. It makes it easy to monitor production.

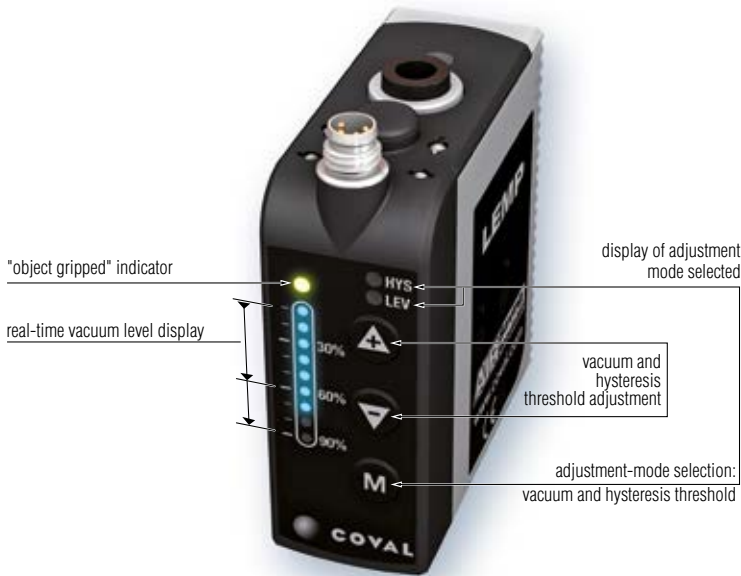

#### Stand-alone or Island Modules?

Stand-alone modules are suitable for the most common applications; one module controls one or more suction cups which all operate according to the same sequence.

When several suction cups are operating according to different sequences, multiple modules are required, which can be:

- several stand-alone modules,
- an island of these modules with an internal common pressure unit.

The diagrams below help in the selection:

- Stand-alone modules are complete, with the integrated pressure regulator
- in an island, the integrated regulator is absent: to maintain the advantage of economical and silent operation, it is recommended to reduce the pressure of the island's common pressure unit to 4 bar.

#### 4.5 to 7 bar network pressure

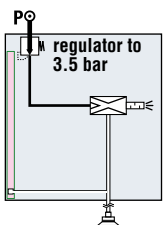

#### network pressure 4 bar

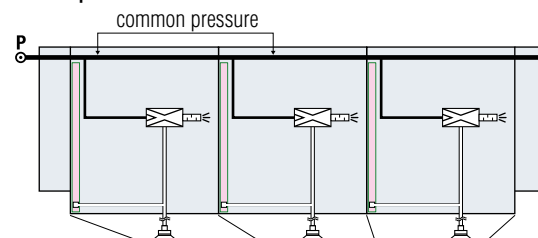

**P optimal = 4 bar**  
(operation at 4-7 bar)



island of 3 modules  
supplying suction cups



#### Select Vacuum Level and Nozzle Diameter

##### ■ Airtight products handling: glass, plastic, coated wood, sheet metal...

Because vacuum leaks are limited, the vacuum level to be used may be high: between 50% to 80%, to be generated by a 85% max. vacuum level venturi.

Taking into account the volume to be emptied and the response time to do so, the chart below is a guide towards the most economical nozzle and gives the air suction flow.

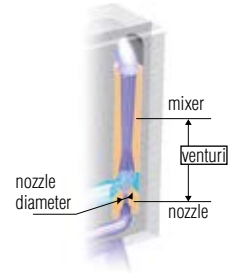

##### ■ Porous products handling: cardboard, raw wood, pastries...

Significant porosity and/or surface vacuum leaks are to be expected. For handling, a vacuum level between 30% to 55% is the best compromise, to be generated by a 60% max. vacuum level venturi.

The chart below is a first indication towards the most economical nozzle ID, to be completed by a product leak flow measurement.

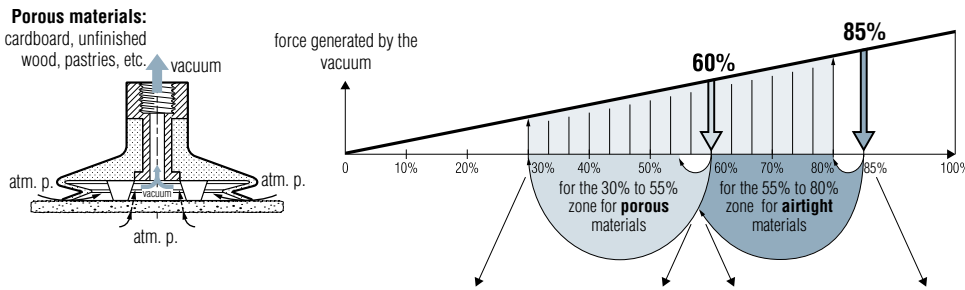

Porous Objects ▶ Maximum Vacuum Level: 60%								
Time to create vacuum (seconds) for a volume of 1 liter								
vacuum achieved	30%	35%	40%	45%	50%	55%	Air consumed (SCFM)	Air drawn in (SCFM)
ø nozzle								
1.0 mm	0.66	0.83	1.04	1.31	1.70	2.35	1.55	1.34
1.2 mm	0.41	0.52	0.66	0.83	1.07	1.49	2.30	2.54
1.4 mm	0.27	0.34	0.43	0.54	0.70	0.97	3.18	3.25

Airtight Objects ▶ Maximum Vacuum Level: 85%								
Time to create vacuum (seconds) for a volume of 1 liter								
vacuum achieved	55%	60%	65%	70%	75%	80%	Air consumed (SCFM)	Air drawn in (SCFM)
ø nozzle								
1.0 mm	1.76	2.04	2.38	2.80	3.33	4.09	1.55	1.02
1.2 mm	1.13	1.31	1.53	1.80	2.15	2.64	2.30	1.59
1.4 mm	0.73	0.85	0.99	1.16	1.38	1.70	3.18	2.47

#### Select with or without Vacuum Switch

For common applications, the vacuum switch is needed, with the dialogue face for digital display and adjustment.

However, some applications may just require a simple operation, without an "object gripped" return signal. The simplified version may then be chosen, with no vacuum switch, display, or adjustment.

#### Exhaust manifold: option E

The LEMP mini vacuum pumps can be equipped with the "exhaust manifold" option, which provides a G1/8"-F connection to the exhaust in order to add a silencer, transfer the exhaust outside the work area or to avoid air discharge near the workpiece (LEMP\_\_E version).

This option must be specified at time of ordering as it cannot be added later.

**Note:** The design of the exhaust manifold and vacuum pumps do not guarantee the complete sealing of the exhaust and therefore cannot be used in a "clean room" environment.

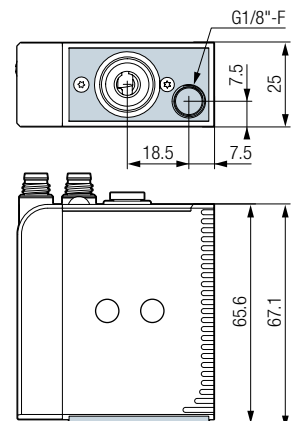





Part numbers for an island assembly or components in an island

Part numbers for stand-alone units

**LEMP 60 X 12 VA - B3**

VACUUM LEVEL	
60% max. vacuum → porous objects	<b>60</b>
85% max. vacuum → airtight objects	<b>90</b>

NOZZLE DIAMETER	
Ø 1 mm nozzle	<b>10</b>
Ø 1.2 mm nozzle	<b>12</b>
Ø 1.4 mm nozzle	<b>14</b>

VACUUM SWITCH	
<b>VA</b>	<ul style="list-style-type: none"> <li>Electronic vacuum switch with digital display and adjustment</li> </ul> 
<b>VO</b>	<ul style="list-style-type: none"> <li>No vacuum switch and no adjustment</li> </ul> 

EXHAUST	
Open (integrated silencer)	<b>-</b>
Exhaust manifold (G1/8"-F)	<b>E</b>

#### ISLAND ASSEMBLIES

<b>B2</b>		LEMP_X____ <b>B2</b> island assembly with 2 identical modules.
<b>B3</b>		LEMP_X____ <b>B3</b> island assembly with 3 identical modules.
<b>B4</b>	...	

If the planned island contains different module types, it must be ordered as separate components in order to then be assembled on site according to the arrangement suitable to the application.

#### COMPONENTS FOR THE ISLAND TO BE ASSEMBLED

<b>B</b>		LEMP_X____ <b>B</b> Module that can be grouped (complete with integrated grouping screw).
		Set of ends for a complete group, with grouping screw and common pressure unit plug.
<b>PART NO.: LEMSETA</b>		

#### EXAMPLE COMPOSITE PART NUMBER FOR AN ISLAND ASSEMBLY:

##### ■ LEMP60X14VAB3

LEMP island assembly, containing 3 x 60% max. vacuum modules, Ø1.4 mm nozzle and vacuum switch.

#### ORDER EXAMPLE FOR AN ISLAND TO BE ASSEMBLED:

##### ■ LEMP60X10VAB

##### ■ LEMP90X12VAB

##### ■ LEMP60X14VAB

##### ■ LEMSETA

→ 3 LEMP modules for a group, of different types.

→ Set of ends for island.

#### REFERENCE EXAMPLE COMPOSED OF A STAND-ALONE MODULE:

##### ■ LEMP60X12VA

Stand-alone LEMP Module, 60% max. vacuum, Ø1.2 mm nozzle and vacuum switch.

#### Accessory

Protection for standalone mini vacuum pumps LEMP\_\_VA (with one M8 connector), Part No.: **80004409**

The COVER is made of silicone and serves as a protective sleeve for vacuum pumps, protecting them against splashing water, in particular during cleaning cycles.

- High level of protection against splashing water.
- Easy to mount and clean.





#### Stand-alone Modules



Side mounting

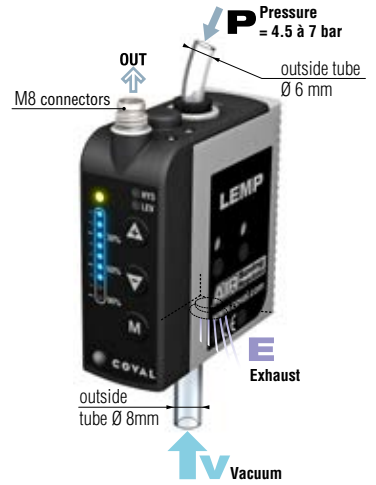
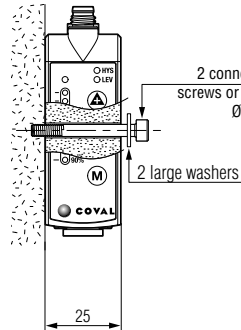
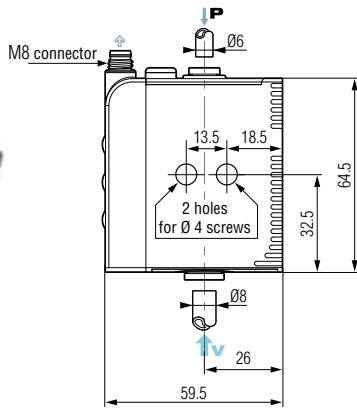

Front mounting

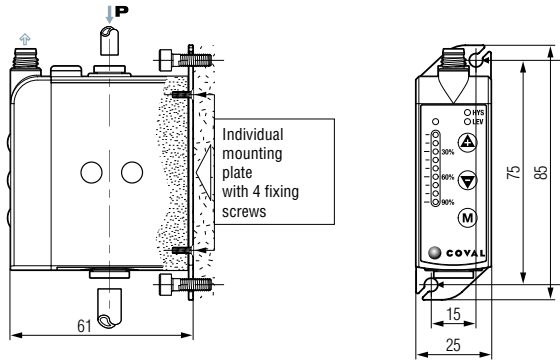

For front mounting, order the necessary kit, in addition to the module:

Front mounting kit:  
1 plate + 4 screws

**Part No.: LEMFIXA**



Mounting on DIN rail

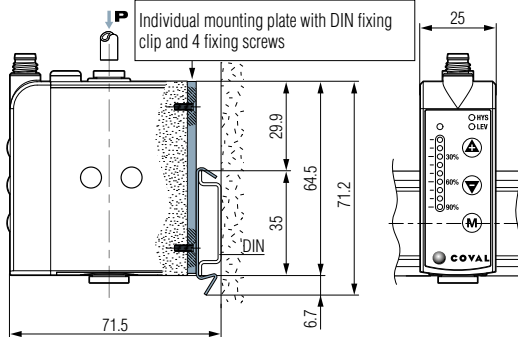

A module can be clipped onto a DIN rail. For this purpose, the module must first be equipped with an individual DIN installation plate, ordered separately:

DIN rail mounting kit:  
1 plate/clip + 4 screws

**Part No.: LEMFIXB**

#### Islands

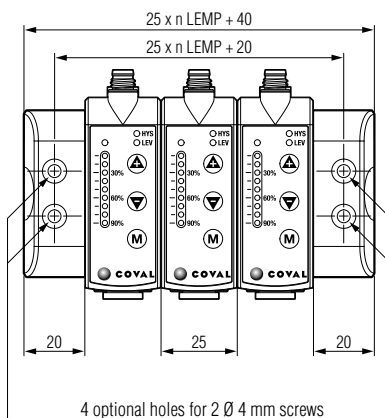

#### Front mounting

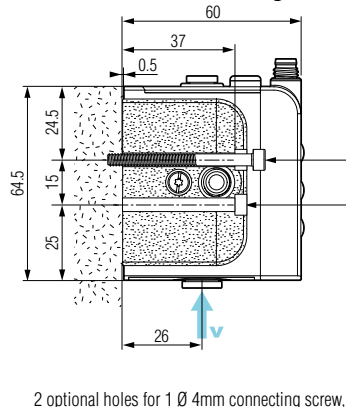

#### Mounting on DIN rail

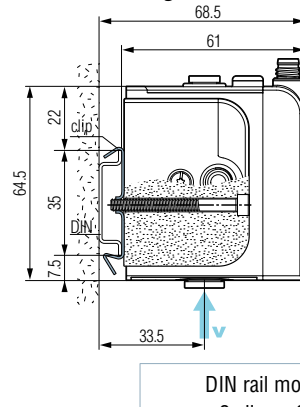

DIN rail mounting kit:  
2 clips + 2 screws

**Part No.: LEMFIXC**



#### Overall Characteristics

- Supply: non-lubricated air filtered to 5 microns according to standard ISO 8573-1:2010 [4:5:4].
- Operating pressure: 4.5 to 7 bar.
- Mini dynamic pressure:
  - stand-alone module: P = 4.5 bar.
  - island modules: P = 4 bar.
- Maximum vacuum: 60% or 85% depending on model.
- Suction rate: 1.02 to 3.25 SCFM depending on model.
- Air consumption: 1.55 to 3.18 SCFM depending on model.
- Electrical protection level: IP 65.
- Weight: 90 to 110 g, depending on model.
- Operating temperature: 32 to 122 °F.
- Materials: PA 6-6 15 %FV, brass, aluminum, NBR.

#### Integrated Vacuum Switch Characteristics

- Measuring range: -1 to 0 bar.
- Precision:  $\pm 1.5\%$  of the range.
- Hysteresis: adjustable from 0% to 100%.
- Output threshold: 1 x T.O.R. in NO.
- Analog output: 1 V DC to 5 V DC on the measuring range.
- Switching power: 125 mA, PNP.
- Threshold status display: 1 green LED.
- Supply voltage 24V DC (regulated  $\pm 10\%$ ).
- Current draw: < 20 mA.
- Protection: against polarity inversions.

#### Integrated Silencer Characteristics

- Noise level: approximately 68 dBA.
- Clog-free silencer.

#### Electrical Connections

##### MODULES WITH VACUUM SWITCH FUNCTION

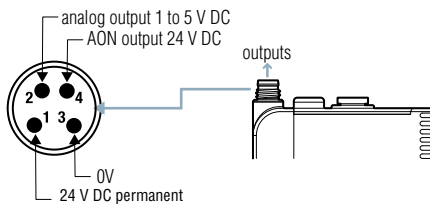

#### Accessories



Power supply cable M8, straight, female, 4-pin – open end:

- **CDM8**: length. 2 m.
- **CDM8N**: length. 0.5 m.

Power supply cable M8, elbow, female, 4-pin – open end:

- **CCM8**: length. 2 m.

#### Characteristics and Connecting an Island

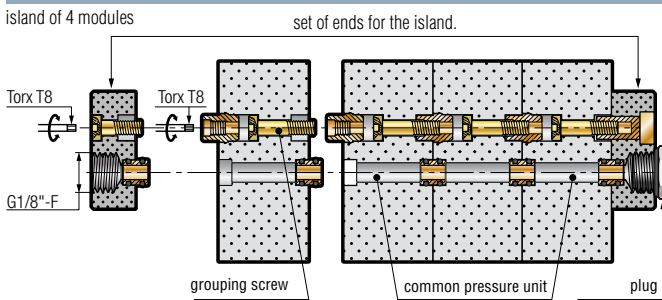

island of 3 modules



#### Maximum number of modules in an island:

- $\varnothing$  1.4 mm nozzle  $\rightarrow$  5 modules
- $\varnothing$  1.2 mm nozzle  $\rightarrow$  7 modules
- $\varnothing$  1 mm nozzle  $\rightarrow$  9 modules

#### Suction Flow Rate / Vacuum Curves

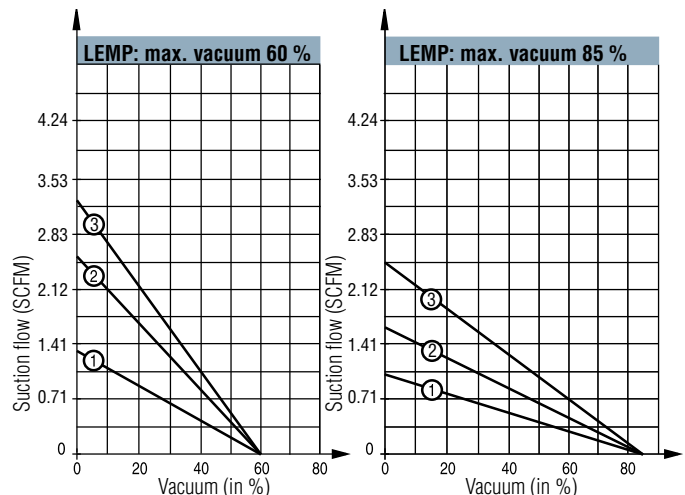

- 1 - LEMP60X10
- 2 - LEMP60X12
- 3 - LEMP60X14

- 1 - LEMP90X10
- 2 - LEMP90X12
- 3 - LEMP90X14

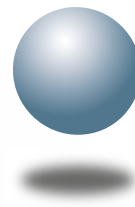

**COVAL**  
vacuum managers

vacuum  
**components**



**A TECHNOLOGICAL PARTNER ON A GLOBAL SCALE**

Located in the southeast region of France, COVAL conceives, manufactures and globally distributes high performance, advanced vacuum automation components and systems for industrial applications in all branches.

COVAL is an ISO 9001: V2015 certified company which offers innovative solutions integrating reliable and optimized components with intelligent functionalities. The focus is to provide the most personalized and economic solution to a given application while assuring a significant improvement in the productivity and the safety for the vacuum users around the world.

COVAL has an ambition for technical excellence and innovation. As a specialist in vacuum automation, COVAL is reputed for offering reliable, personalized, cost effective and productive solutions.

The references of COVAL can be found in several industrial sectors (Packaging, Automotive Industry, Plastic, Graphic, Aeronautic...) where vacuum handling is important for high efficiency and productivity.

COVAL markets its products and services all over Europe, in the United States and South America through its subsidiaries and authorized distribution network. COVAL strives to provide customer driven solutions and gives the best possible treatment to satisfy all its clients.

*For all enquiries from Australia, Africa and Asia kindly contact COVAL head office in France.*



**COVAL S.A.S.**  
Head Office



**COVAL INC.**



**COVAL IBERICA**



**COVAL GERMANY**



**COVAL ITALIA**



**COVAL CHINA**

Distributed by:



ISO 9001  
certified quality  
management system

**COVAL VACUUM TECHNOLOGY INC.**  
901 Jones Franklin Road  
Suite 100  
Raleigh, NC 27606  
Phone : (919) 233-4855  
Fax : (919) 233-4854

[www.coval-inc.com](http://www.coval-inc.com)