

COVAL

vacuum managers

MPXE

Controlled Micro Vacuum Pumps



ADVANCED VACUUM SOLUTIONS

MPXE

Controlled Micro Vacuum Pumps

General Information

Thanks to their low weight and extremely compact design, the **MPXE Series** controlled micro vacuum pumps can be closely integrated with the suction cups to meet the needs of very high speed applications.

They are available as standalone modules or in banks of 1 to 8 modules with common pressure and collectable exhaust. They are equipped with vacuum and blow-off control valves, LEDs for displaying the control valve status, a vacuum check valve, and an analog vacuum level signal.

The analog vacuum level signal and the vacuum check valve allow the vacuum regulation to be managed by the PLC.

In addition, the **MPXE Series** micro-pump range offers 2 blow-off options: standard or powerful. The powerful blow-off can be adjusted via a set screw.



Industry-specific applications

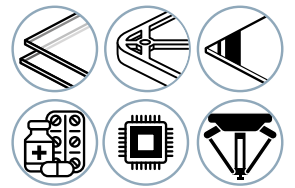

Full scale

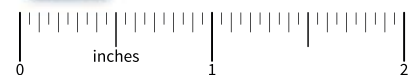

Main Features

- Ultra-compact and lightweight: 12.5 mm wide and 82 g minimum.
- Maximum vacuum: 85%.
- Suction flow rates: - Nozzle Ø 0.7 mm → 0.53 SCFM
- Nozzle Ø 1.0 mm → 0.92 SCFM
- Vacuum control: NC (Normally Closed) or NO (Normally Open).
- Standard or adjustable powerful blow-off.
- Vacuum check valve.
- Integrated open silencer or exhaust collector.
- Standalone micro vacuum pumps or bankable from 1 to 8 modules with common pressure and collectable exhaust.
- Electronic vacuum switch with analog output 5V DC.
- Standard Input/Output (SIO).

Applications

The compact and lightweight nature of the **MPXE Series** micro vacuum pumps allow installation as close as possible to the suction cups, thereby reducing cycle times and energy consumption.

They are ideal for high speed gripping applications:

- Plastics processing
- Electronics
- Pharmaceutical

...



MPXE

Controlled Micro Vacuum Pumps

General Information



Ultra-compact and lightweight design

- 12.5 mm wide
- 82 g minimum
- Volume: 71 cm³



Vacuum generation with single-stage Venturi pump

- Short evacuation times
- No moving parts
- Dust resistant
- No maintenance required



Simple and efficient HMI

Control status LEDs:

- Green LED: vacuum control
- Orange LED: blow-off control



Inputs / Outputs Digital (SIO)

- JST male connector 5 pins with 1 mm pitch, type NSH



Vacuum check valve

Open clog-free silencer or exhaust collector depending on the version



Available configurations

- **Standalone module:** ultra-thin and lightweight micro vacuum pump.



- **Bank from 1 to 8 modules** with common pressure and collectable exhaust.



MPXE

Controlled Micro Vacuum Pumps

Integration and Performance



Integrated Functions

The **MPXE Series** micro vacuum pumps integrate all the necessary functions into a compact footprint for a simple, efficient solution adapted to each application:

- ❶ Vacuum solenoid valve
- ❷ Single-stage Venturi pump
- ❸ Open silencer or exhaust collector
- ❹ Vacuum check valve
- ❺ Electronic vacuum switch
- ❻ Blow-off solenoid valve
- ❼ 200 µm filter screen

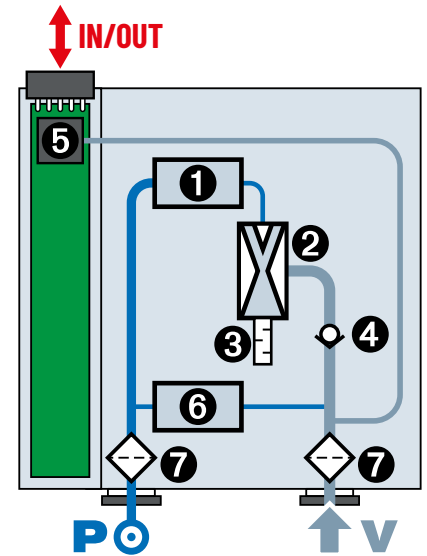

Performance Determined by the Venturi Pump's Nozzle Diameter

The table specifies the performance levels and evacuation times generated for each nozzle diameter available.

Vacuum reached Nozzle dia. (mm)	Evacuation time ⁽¹⁾ (s) of a volume of 5 cl ⁽²⁾				Max. vacuum (%)	Air drawn in (SCFM)	Air consumed (SCFM)	Air pressure level (bar)
	50%	60%	70%	80%				
0.7	0.15	0.25	0.42	0.70	85	0.53	0.78	3.7
1.0	0.09	0.14	0.24	0.37	85	0.92	1.55	3.7

(1) Out of valve response time. (2) Example of a 5 cl volume: 4 suction cups 1.5 bellows Ø 25 (VSA25) + 4 airlines 4x6 mm lg 600 mm + 1 airline 4x6 mm lg 500 mm.

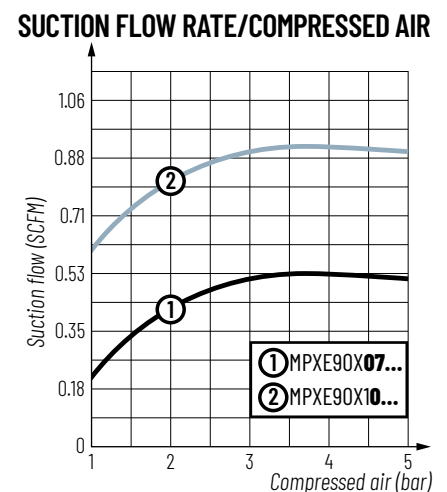
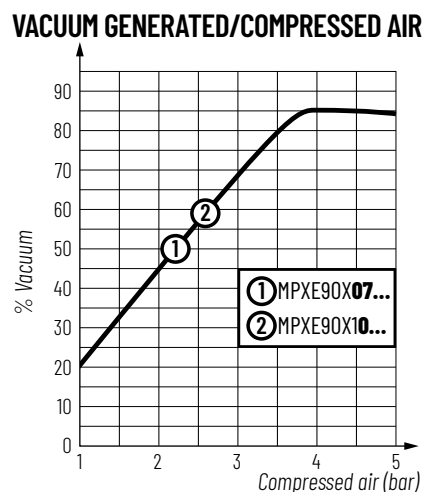
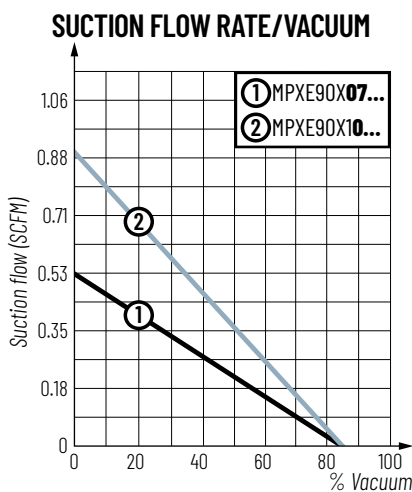
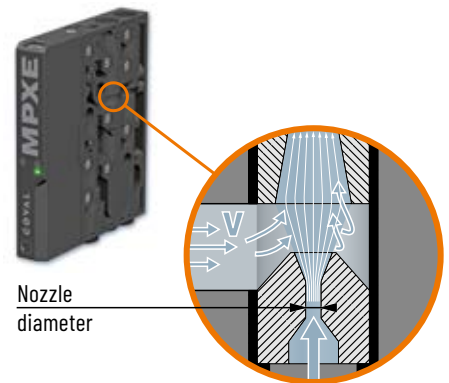

MPXE

Controlled Micro Vacuum Pumps

Selection Guide



Vacuum Control: 2 Solutions

Model MPXE_S:

Vacuum pump with **NC** vacuum control and **NC** blow-off.

In the event of power failure, vacuum is no longer generated. In the event of compressed air failure, the vacuum is no longer maintained.

- NC blow-off and vacuum control: solenoid valves.

NC vacuum control
Standard blow-off (F1)

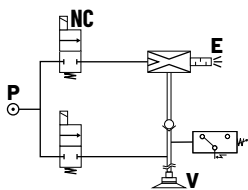

P: Pressure / Compressed Air V: Vacuum / Suction Cup E: Exhaust

NC vacuum control
Adjustable powerful blow-off (F3)

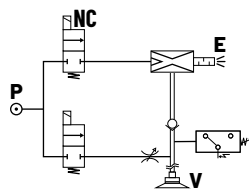

P: Pressure / Compressed Air V: Vacuum / Suction Cup E: Exhaust

Model MPXE_V:

Vacuum pump with **NO** vacuum control and **NC** blow-off.

In the event of power failure, vacuum is still generated: object is held in place → fail-safe.

In the event of compressed air failure, the vacuum is no longer maintained.

- NO vacuum control solenoid valve.
- NC blow-off control solenoid valve.

NO vacuum control
Standard blow-off (F1)

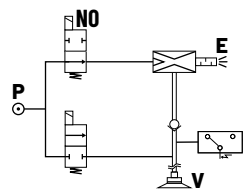

P: Pressure / Compressed Air V: Vacuum / Suction Cup E: Exhaust

NO vacuum control
Adjustable powerful blow-off (F3)

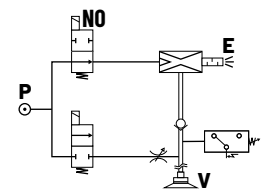

Blow-off Function

The MPXE micro vacuum pumps offer 2 blow-off versions to meet all application needs:

■ Standard blow-off (MPXE_F1 version)

The blow-off flow is directed into the vacuum network, ensuring the release of parts in most applications.

→ Network pressure (blow-off flow rate of 0.24 SCFM at 3.7 bar).

■ Adjustable powerful blow-off (MPXE_F3 version)

This blow-off version allows for very rapid release of parts in cases where the pump cannot be positioned close to the suction cups or to minimize cycle times. The MPXE_F3 features an adjustment screw with a locking nut to tailor the power as needed. → Network pressure with amplification valve (adjustable blow-off flow rate from 0.56 to 1.94 SCFM at 3.7 bar).

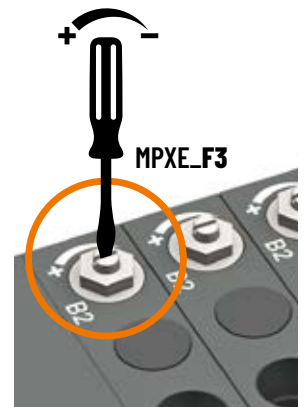

Electrical Connections and Cables

JST male connector 5 pins with 1 mm pitch, type NSH



1	brown	24V DC
2	white	24V DC suction command ⁽¹⁾
3	blue	0V - GND
4	black	Vacuum level signal - analog output 5V DC
5	gray	24V DC blow-off command

(1) 24 V DC suction command, depending on version:

- S: 24 V DC vacuum control
- V: 24 V DC vacuum off command

Accessories for MPXE Micro Vacuum Pumps

Connection Cables

Part No.: CDM8M6PJSTF5PL01

Cable JST 5P NSH to M8 6P straight male A-coded, Lg 10 cm.



Part No.: CDM12M5PJSTF5PL02

Cable JST 5P NSH to M12 5P straight male A-coded, Lg 20 cm.



MPXE

Controlled Micro Vacuum Pumps Configurations



Standalone vs Bank

Standalone MPXE micro vacuum pumps cater to the most common applications: a single micro vacuum pump controls one or several suction cups, all operating in the same sequence.

When multiple suction cups operate in different sequences, several micro vacuum pumps are needed, which can be configured as:

- Multiple standalone micro vacuum pumps;
- Or a bank consisting of 1 to 8 micro vacuum pumps with a shared internal pressure and a collectable common exhaust.

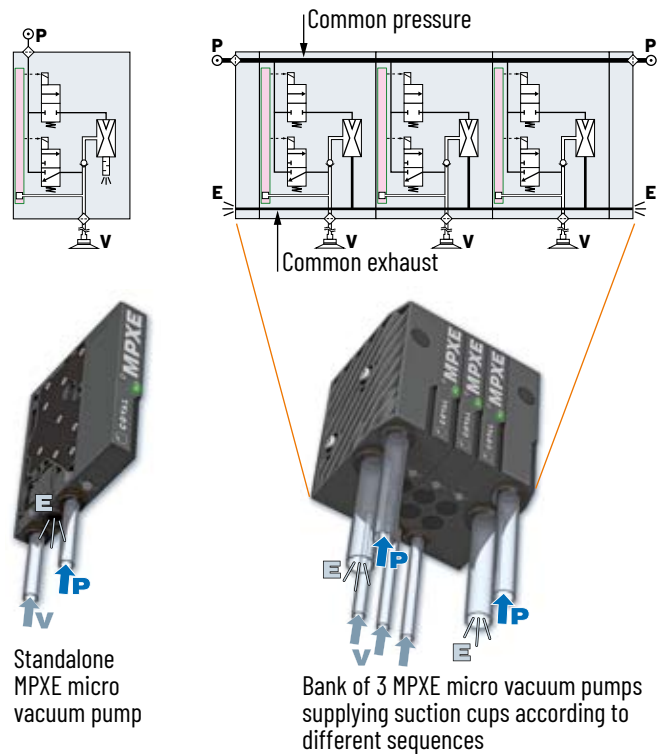

Standalone Version

- Ultra-thin and light

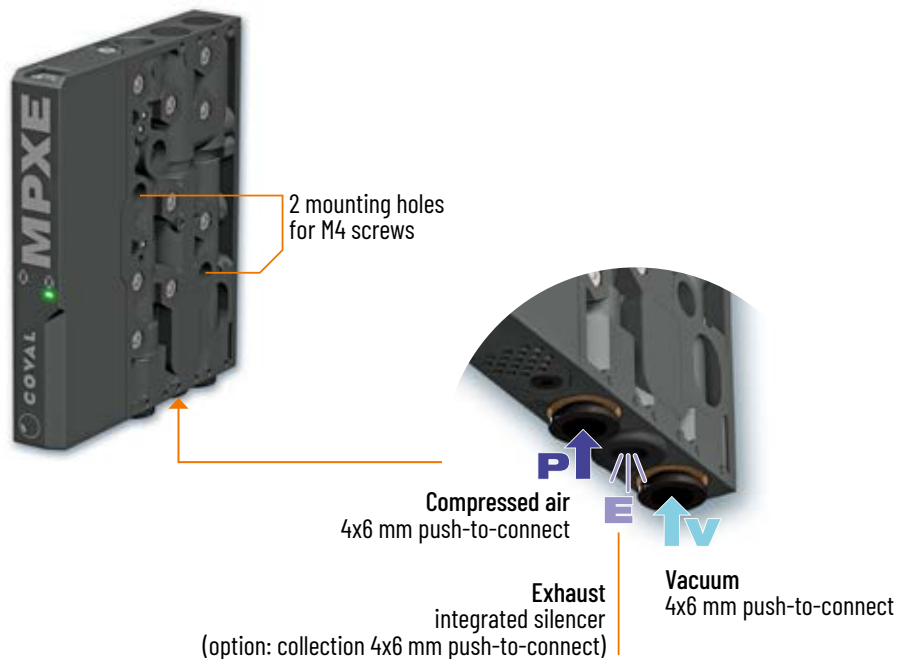

MPXE

Controlled Micro Vacuum Pumps

Configurations



Bankable Version

BANK EQUIPPED WITH SINGLE END SET - LEFT (MPXE___B_L)

- Nozzle Dia. 0.7 mm: 1 to 8 modules per bank
- Nozzle Dia. 1.0 mm: 1 to 4 modules per bank
- 1 x Common Pressure
- 1 x Unrestricted and collectable exhaust

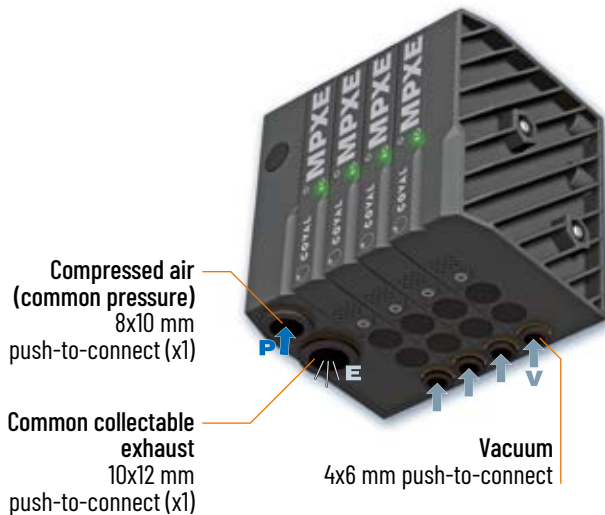

BANK EQUIPPED WITH DOUBLE END SET (MPXE___B_D)

- 1 to 8 modules per bank
- 2 x Common Pressure
- 2 x Unrestricted and collectable exhaust

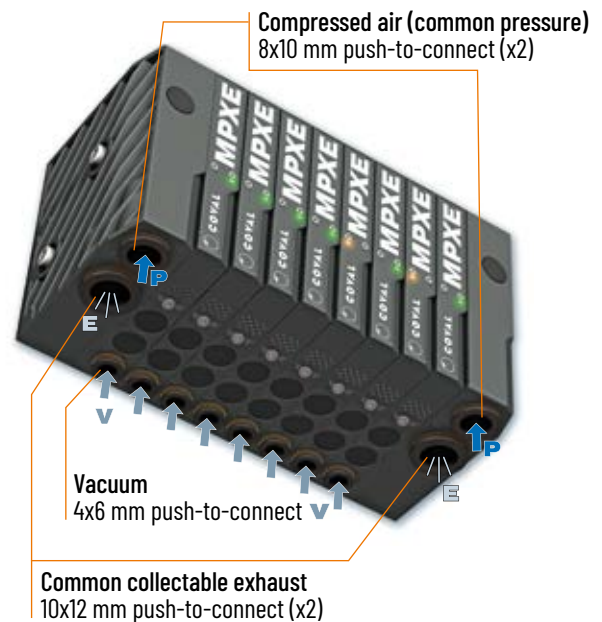

Composition of Banks

Standard banks are composed of 1 to 8 identical **MPXE** vacuum modules in the **MPXE_EB** version, an end set consisting of a head module and a tail module, and assembly screws corresponding to the number of modules in the bank.

The end sets are available in two versions:

- **Single** version – left: 1 x Common Pressure and 1 x Unrestricted and collectable exhaust
- **Double** version: 2 x Common Pressure and 2 x Unrestricted and collectable exhaust

Standard banks are cataloged and delivered assembled.

For banks composed of different MPXE vacuum modules, it is necessary to order the sub-assemblies separately:

- X MPXE micro vacuum pump modules for the bank (version **MPXE_EB**)
- An end set for the bank
- An assembly screw kit

Specific banks are delivered unassembled.

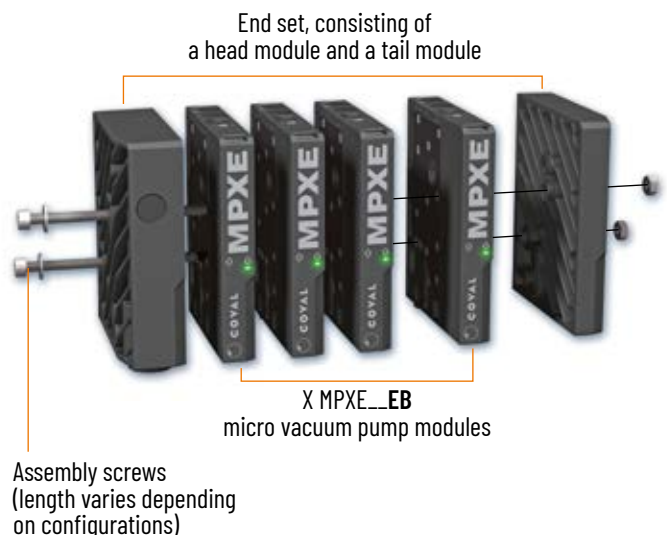

Completing a Bank

It is possible to add an MPXE micro vacuum pump to an existing bank by ordering the desired MPXE micro vacuum pump module in the **EB** version, along with the assembly screw kit corresponding to the new number of modules in the bank.

MPXE

Controlled Micro Vacuum Pumps

Configuring a Vacuum Pump



STANDALONE MPXE MICRO VACUUM PUMP

	MPXE90X 10 S L15 P R2 F1 E	
NOZZLE DIA.		BLOW-OFF
0.7 mm dia. 07		Standard blow-off F1
1.0 mm dia. 10		Adjustable powerful blow-off F3
GENERATOR CONTROL		EXHAUST COLLECTION
Vacuum NC and blow-off NC S		X Without
Vacuum NO and blow-off NC V		E With

Sample part number:

MPXE90X07SL15PR2F1X

MPXE Micro Vacuum Pump, maximum vacuum 85%, nozzle 0.7 mm dia., controlled by an NC vacuum solenoid valve and an NC blow-off solenoid valve, 5-pin JST connector, with standard blow-off and open silencer.

MPXE MICRO VACUUM PUMPS IN BANK

	MPXE90X 10 S L15 P R2 F1 EB4 L	
NOZZLE DIA.		BLOW-OFF
0.7 mm dia. 07		Standard blow-off F1
1.0 mm dia. 10		Adjustable powerful blow-off F3
GENERATOR CONTROL		NUMBER OF MODULES
Vacuum NC and blow-off NC S		EB1 Bank of 1 MPXE module
Vacuum NO and blow-off NC V		EB2 Bank of 2 MPXE modules
		EB3 Bank of 3 MPXE modules
		EB4 Bank of 4 MPXE modules
		EB5 Bank of 5 MPXE modules
		EB6 Bank of 6 MPXE modules
		EB7 Bank of 7 MPXE modules
		EB8 Bank of 8 MPXE modules
		BANK END SETS
		L Single Left End Set for a bank of 1 to 4 MPXE modules with a 1.0 mm nozzle, and up to 8 MPXE modules with a 0.7 mm nozzle.
		▪ 1 x common pressure connection, push-to-connect 8x10 mm
		▪ 1 x Exhaust collector, push-to-connect 10x12 mm
		D Double End Set for a bank of 1 to 8 MPXE modules.
		▪ 2 x common pressure connections, push-to-connect 8x10 mm
		▪ 2 x Exhaust collectors, push-to-connect 10x12 mm

Sample part number:

MPXE90X10VL15PR2F3EB8D

Assembled bank of 8 MPXE modules, maximum vacuum 85%, 1.0 mm nozzle, controlled by an NO vacuum solenoid valve and an NC blow-off solenoid valve, 5-pin JST connector, with adjustable powerful blow-off and equipped with a double end set.



MPXE90X07SL15PR2F1EB4L

Assembled bank of 4 MPXE modules, maximum vacuum 85%, 0.7 mm nozzle, controlled by an NC vacuum solenoid valve and an NC blow-off solenoid valve, 5-pin JST connector, with standard blow-off and equipped with a simple left end set.



Accessories

Mounting Accessories for Standalone MPXE Micro Vacuum Pumps

- Part No. **MPXFIXA**
Front panel installation kit for standalone MPXE module (1 plate + 4 fastening screws)
- Part No. **MPXFIXB**
DIN rail installation kit for standalone MPXE module (1 mounting plate + 5 screws and 1 clip)

Mounting Accessories for MPXE Micro Vacuum Pump Banks

- Part No. **MPXFIXC**
DIN rail mounting kit for MPXE bank (2 clips + 2 fastening screws)
- Part No. **MPXFIXD**
Front panel mounting kit for MPXE bank (2 plates + 4 fastening screws)

Connection Cables for MPXE Micro Vacuum Pumps

- Part No. **CDM8M6PJSTF5PLO1**
Cable JST 5P NSH to M8 6P straight male A-coded, Lg 10 cm.
- Part No. **CDM12M5PJSTF5PLO2**
Cable JST 5P NSH to M12 5P straight male A-coded, Lg 20 cm.

MPXE

Controlled Micro Vacuum Pumps

Build Your Own Bank Assembly

To build a custom bank assembly containing different MPXE micro vacuum pumps, you need to order the parts below separately.

Note: Custom bank assemblies come unassembled.



1 Select the Bank End Set

MPXSETAL	Single Left Bank End Set: <ul style="list-style-type: none"> Head module on the left with 8x10 mm pressure connection and 10x12 mm exhaust collector. Tail module on the right (simple). → For a bank of 1 to 4 MPXE micro vacuum pump modules with a 1.0 mm nozzle, and up to 8 modules with a 0.7 mm nozzle.
MPXSETAD	Double Bank End Set: <ul style="list-style-type: none"> Head and tail modules with 8x10 mm pressure connection and 10x12 mm exhaust collector. → For a bank of 1 to 8 MPXE micro vacuum pump modules.

2 Select the Micro Vacuum Pump Modules for Bank

MPXE90X 10	S	L15	P	R2	F1	EB
NOZZLE DIA.		GENERATOR CONTROL			BLOW-OFF	
0.7 mm dia. 07	S	Vacuum NC and blow-off NC			F1	Standard blow-off
1.0 mm dia. 10	V	Vacuum NO and blow-off NC			F3	Adjustable powerful blow-off



3 Select the Assembly Screw Kit

Assembly Screw Kit for a Single Left Bank Version	
MPXSETVB1L	For a bank of 1 MPXE module
MPXSETVB2L	For a bank of 2 MPXE modules
MPXSETVB3L	For a bank of 3 MPXE modules
MPXSETVB4L	For a bank of 4 MPXE modules
MPXSETVB5L	For a bank of 5 MPXE modules
MPXSETVB6L	For a bank of 6 MPXE modules
MPXSETVB7L	For a bank of 7 MPXE modules
MPXSETVB8L	For a bank of 8 MPXE modules

Assembly Screw Kit for a Double Bank Version	
MPXSETVB1D	For a bank of 1 MPXE module
MPXSETVB2D	For a bank of 2 MPXE modules
MPXSETVB3D	For a bank of 3 MPXE modules
MPXSETVB4D	For a bank of 4 MPXE modules
MPXSETVB5D	For a bank of 5 MPXE modules
MPXSETVB6D	For a bank of 6 MPXE modules
MPXSETVB7D	For a bank of 7 MPXE modules
MPXSETVB8D	For a bank of 8 MPXE modules



MPXE

Controlled Micro Vacuum Pumps

Dimensions and Installation Options



Standalone Module

LATERAL INSTALLATION

2 x 4.2 mm dia.
(for two Ø 4 mm through screws or bolts with large washers).

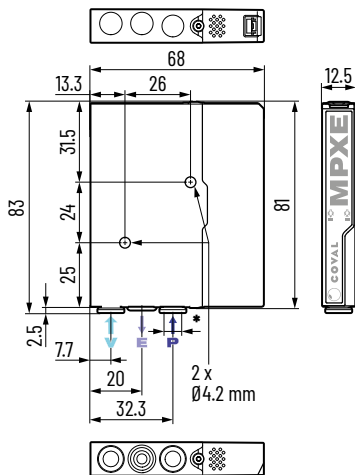

* Push-to-connect:

- V (vacuum / suction cup): 4x6 mm
- E (exhaust collection, E option): 4x6 mm
- P (pressure / compressed air): 4x6 mm

MOUNTING FROM FRONT

2 x 4.5 mm dia.
(for M4 screws)

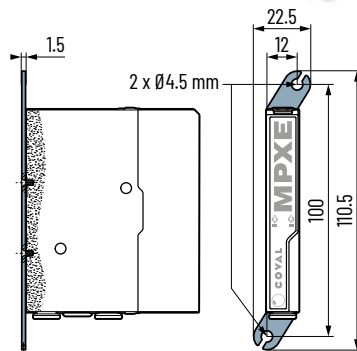

Individual mounting plate with its 4 fastening screws

For front panel installation, order the following installation kit:

Part No.: **MPXFIXA**
(1 plate + 4 fastening screws)

INSTALLATION ON DIN RAIL

For a static installation (e.g., in a cabinet), an MPXE micro vacuum pump can be mounted on a DIN rail.

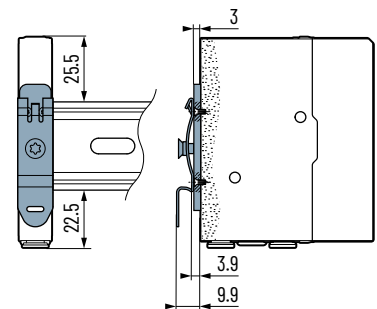

In this case, it must be equipped with an installation clip that is to be ordered separately:

Part No.: **MPXFIXB**
(1 bracket + 1 clip + 5 fastening screws)

Bank

MPXE...B_L VERSION

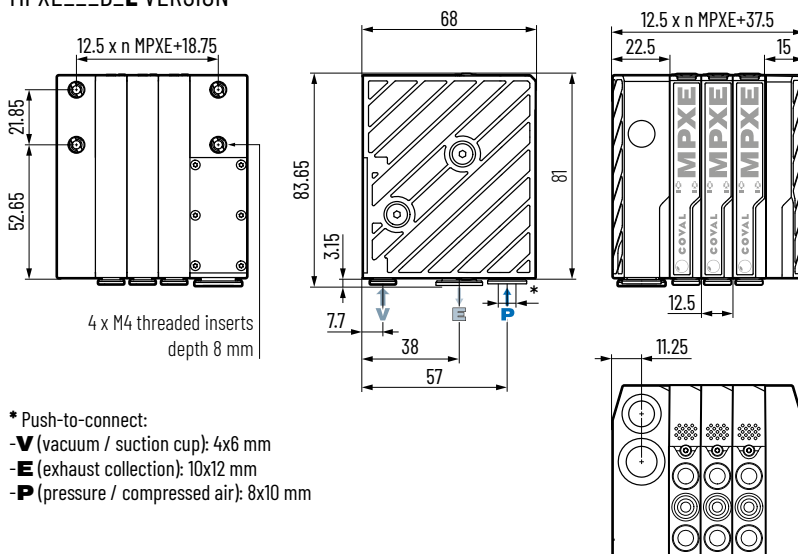

* Push-to-connect:

- V (vacuum / suction cup): 4x6 mm
- E (exhaust collection): 10x12 mm
- P (pressure / compressed air): 8x10 mm

Dimensions of the MPXE_F3 Option (Adjustable Powerful Blow-off)

The MPXE micro vacuum pumps in the F3 version feature an adjustment screw with a locking nut to adjust the blow-off power.



Note: All dimensions are in mm.



You can access 3D files of all COVAL products in formats compatible with the main CAD software on COVAL's website www.coval.com

MPXE

Controlled Micro Vacuum Pumps

Dimensions and Installation Options



MPXE...B...D VERSION

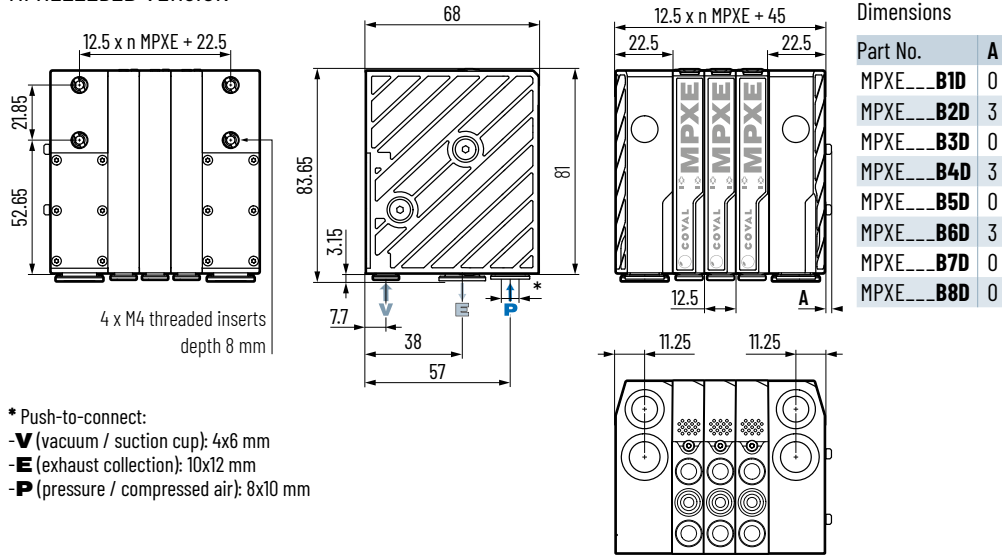

- * Push-to-connect:
- V (vacuum / suction cup): 4x6 mm
- E (exhaust collection): 10x12 mm
- P (pressure / compressed air): 8x10 mm

Dimensions of the MPXE_F3 Option (Adjustable Powerful Blow-off)

The MPXE micro vacuum pumps in the F3 version feature an adjustment screw with a locking nut to adjust the blow-off power.

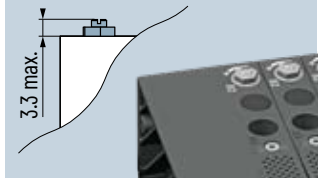

Note: All dimensions are in mm.

MOUNTING FROM REAR

4 x M4 threaded inserts depth 8 mm



MPXE...B...L VERSION

4 x M4 threaded inserts depth 8 mm

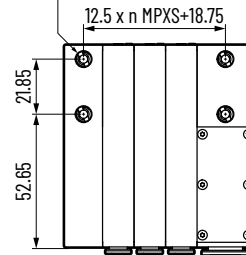

MPXE...B...D VERSION

4 x M4 threaded inserts depth 8 mm

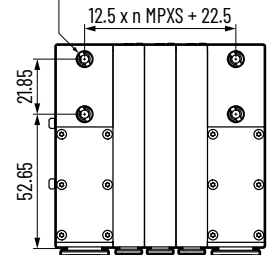

MOUNTING FROM FRONT

4 x 4.5 mm dia. (for M4 screws)

For front panel installation, order the following installation kit:

Part No.: **MPXFIXD**
(2 plates + 4 fastening screws)

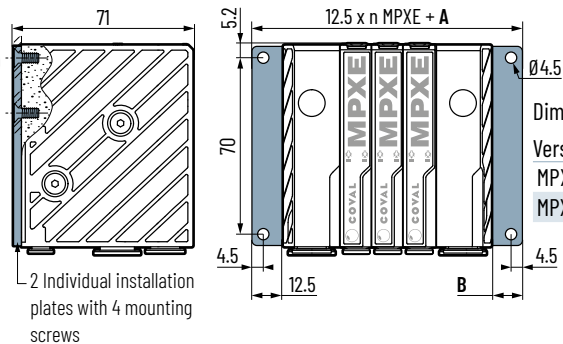

INSTALLATION ON DIN RAIL

The bank can be mounted on a DIN rail for a static installation (e.g. in a cabinet).

In this case, it must be equipped with an installation clip that is ordered separately:

Part No.: **MPXFIXC**
(2 clips + 2 fastening screws)

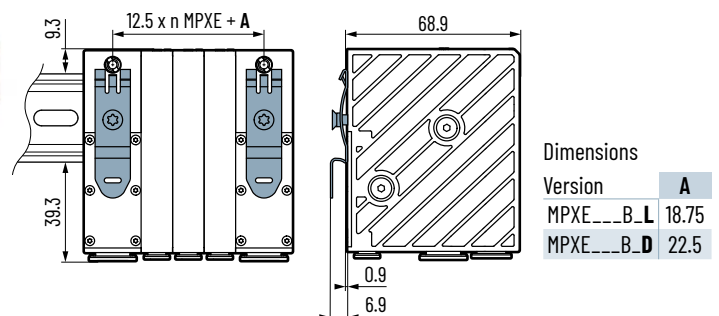



General characteristics

- Supply: non-lubricated air, filtered to 5 microns, according to standard ISO 8573-1:2010 [3:4:3].
- Operating pressure: from 3.5 to 7 bar.
- Optimal dynamic pressure per module: 3.7 bar (*bank supply pressure must be adjusted according to the number of modules to ensure 3.7 bar dynamic pressure / module*).
- Standard blow-off (MPXE_**F1**): network pressure (blow-off flow rate of 0.24 SCFM at 3.7 bar).
- Adjustable powerful blow-off (MPXE_**F3**): network pressure with valve (flow rate adjustable from 0.56 to 1.94 SCFM at 3.7 bar).
- Pressure connection:
 - Standalone vacuum pumps: 4x6 mm push-to-connect with 200 µm filter screen.
 - Bank: 8x10 mm push-to-connect with 200 µm filter screen.
- Vacuum connection: 4x6 mm push-to-connect with 200 µm filter screen.
- Common collectable exhaust:
 - Standalone vacuum pumps: 4x6 mm push-to-connect.
 - Bank: 10x12 mm push-to-connect.
- Noise level:
 - Standalone vacuum pumps: max 66 dBA
 - Bank of 1 to 4 vacuum pumps: max 74 dBA
 - Bank of 5 to 8 vacuum pumps: max 82 dBA
- Protection rating: IP40.
- Max. operating frequency: 4 Hz.
- Endurance: 30 million cycles.
- Weight:
 - Standalone vacuum pumps:
 - MPXE_**F1**: 85 g
 - MPXE_**F3**: 90 g.
 - Bank:
 - MPXE_B_**L**: 82 g (F1) or 86 g (F3) X number of stand-alone modules + 145 g for ends set.
 - MPXE_B_**D**: 82 g (F1) or 86 g (F3) X number of stand-alone modules + 185 g for ends set.
- Operating temperature: from 32 to 122°F.
- Storage temperature: from 14°F to 140°F.
- Materials: PA 6.6 GF, aluminum, stainless steel, brass, steel, NBR, PC+ABS, FKM, POM, PU. Housing materials comply with the requirements of UL standard 94 class HB.

Electrical controls

- Control voltage: 24V DC (regulated $\pm 10\%$), PNP.
- Max. consumption: 60 mA (1.4 W) per vacuum and blow-off solenoid valve.
- Valve response time:
 - opening: 20 ms.
 - closure: 15 ms.

Integrated electronics

- 24 V DC power supply (regulated $\pm 10\%$), protected against reversed polarity.
- Typical current consumption: < 10 mA / max. 16 mA.
- Measuring range: 0 to 99 % vacuum.
- Measurement accuracy: $\pm 2\%$ of the range, compensated for temperature.
- Protected against reversed wiring and polarity.
- Protection against short circuits.
- Inputs switching type: PNP.
- LEDs for visualization of the controls:
 - Model **MPXE_S**, Vacuum pump with NC vacuum control and NC blow-off:
 - Green LED: vacuum control.
 - Orange LED: blow-off control.
 - Model **MPXE_V**, Vacuum pump with NO vacuum control and NC blow-off:
 - No LEDs: vacuum control.
 - Both LEDs on: blow-off control.

Electrical connections

- JST connector 5 pins with 1 mm pitch type NSH, A-Coded.
- SIO (Standard Inputs Outputs) operation.

Output signal

- Vacuum level signal, analog output 5V DC: from 1 to 4V DC from 0 to 90% of vacuum.

MPXE

Controlled Micro Vacuum Pumps

Applications



MPXE, MPXS: 2 Complementary Series

COVAL offers a variant of the MPXE controlled micro vacuum pumps with the MPXS Series controlled communicating micro vacuum pumps.

	MPXE	MPXS
Vacuum control (NC or NO)	■	■
Blow-off control (NC)	■	■
Automatic timed blow-off	/	■
Powerful blow-off (F3)	□	□
Electronic vacuum switch	■	■
Display	/	■
Vacuum level signal, analog output 5 V DC	■	/
Output signal "Object Gripped", Digital output 24 V DC (PNP/NPN)	/	■
Vacuum check valve	■	■
Automatic vacuum regulation (ASC)	/	■
Electrical Connectors:		
- JST 5-pin	■	/
- M8-6-pin male	/	■
Standalone or in Bank Module	■	■
IO-Link	/	■

The **MPXS** series micro vacuum pumps offer a new approach to vacuum handling in numerous domains: robotics, plastic molding, pharmaceutical, etc..

Optimized to serve small and medium sized suction cups, the **MPXS** series helps to simplify the installation while integrating all control functions into a single lightweight micro-module, placed close to the suction cups.

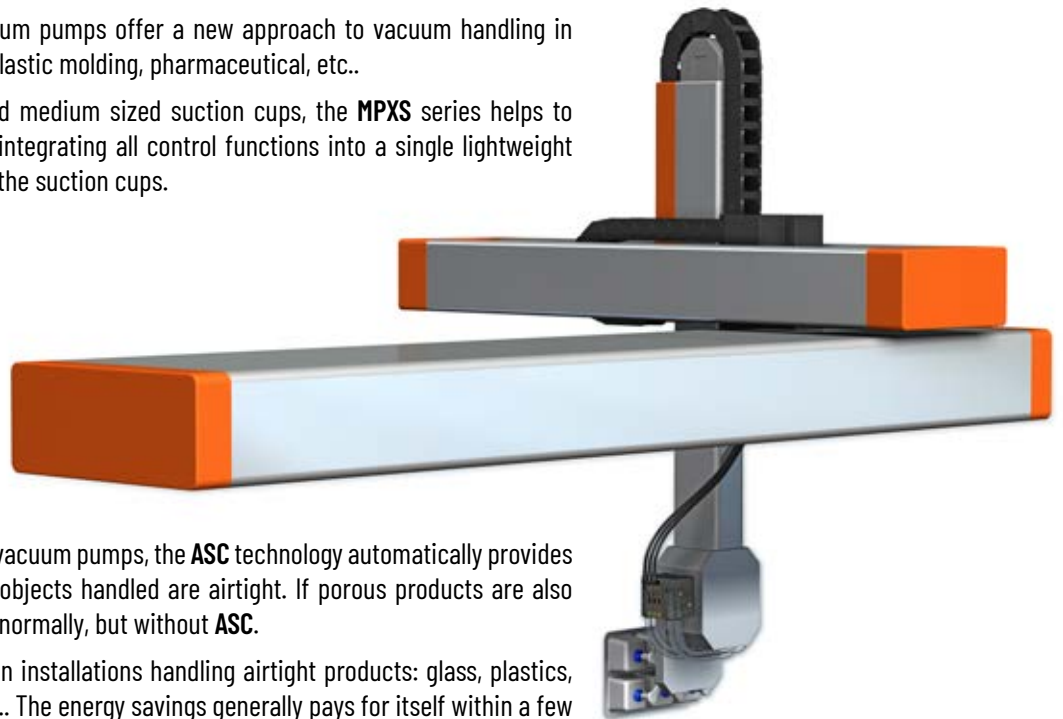

Integrated in all **MPXS** micro-vacuum pumps, the **ASC** technology automatically provides 60-99% energy savings when objects handled are airtight. If porous products are also handled, production continues normally, but without **ASC**.

The **MPXS** series is applied on installations handling airtight products: glass, plastics, coated wood, metal sheets, etc.. The energy savings generally pays for itself within a few months.

The **MPXS** series may also be applied to mixed machines that handle airtight and porous objects: the adaptation to the type of product is totally automatic.

■: Standard □: Option



COVAL
vacuum managers

vacuum
components



A TECHNOLOGICAL PARTNER ON A GLOBAL SCALE

Located in the South of France, COVAL SAS designs, produces, and markets high-performance vacuum components and systems for industrial applications in all sectors worldwide.

An ISO 9001: V2015 certified company, COVAL innovates globally in vacuum handling. Our optimized components integrate intelligent and reliable functionalities, adapt to your industrial context, and safely improve your productivity.

With a strong spirit of innovation and technological advancements, the COVAL team is now recognized as an expert in developing reliable, economical, and productive custom solutions.

COVAL's references are found in major industrial sectors such as packaging, food processing, automotive, plastics, aerospace, and robotics, where vacuum handling is crucial for efficiency and productivity.

COVAL markets its products and services worldwide through its subsidiaries and authorized distributor network. Always attentive to its customers, COVAL supports the implementation of its solutions with a continuous and attentive relationship.

Visit the following section on COVAL's website:
contacts > commercial network
to view the most current list.



COVAL S.A.S.
Head Office



COVAL INC.



COVAL IBERICA



COVAL ITALIA



COVAL CHINA

Distributed by:



Certified quality
management system

COVAL VACUUM TECHNOLOGY INC.
901 Jones Franklin Road
Raleigh, NC 27606
Phone : (919) 233-4855
Fax : (919) 233-4854

www.coval-inc.com