

**For your safety, please read the following before using.**

- ① Do not use corrosive or flammable gas or liquid with this product.
- ② Please use within the operating pressure range. Do not apply pressure beyond recommended maximum pressure, permanent damage to the pressure sensor may occur.
- ③ Do not drop, hit or allow excessive shock. Even if switch body appears undamaged, internal components may be broken and can cause malfunction.
- ④ Turn power off before connecting wiring. Wrong wiring or short circuit will damage and / or cause malfunction.
- ⑤ Do not use in environment containing steam or oil vapor.
- ⑥ This product is not explosion-proof rated. Do not use in atmosphere containing flammable or explosive gases.
- ⑦ Wiring for pressure sensor should avoid power source line and high voltage line. If use in the same circuit, noise may cause malfunction.

SPECIFICATIONS		PSA100C (Vacuum)
Rated pressure range		0.00 ~ -1.00 bar
Set pressure range		0.10 ~ -1.00 bar
Withstand pressure		3 bar
Fluid		Filtered air, Non-corrosive/Non-flammable gases
Set pressure resolution		0.01bar
Power supply voltage		12 to 24V DC $\pm$ 10%, Ripple (P-P) 10% or less
Current consumption		$\leq$ 60mA
Switch output		PNP:Open collector 2 outputs Max. load current: 125mA Max. supply voltage: 24V DC Residual voltage: $\leq$ 1V
Repeatability (Switch output)		$\leq$ $\pm$ 1%F.S. $\pm$ 0.01bar
Hysteresis	Hysteresis mode	Adjustable
	Window comparator mode	Fixed (0.03bar)
Response time		$\leq$ 2.5ms (chattering-proof function : 24ms, 192ms and 768ms selections)
Output short circuit protection		Yes
Display		3 1/2 digit, 7 segment LED display ( Red ) ( Sampling rate : 5 times / sec. )
Indicator accuracy		$\leq$ $\pm$ 2% F.S. $\pm$ 0.01bar (ambient temperature : 25 $\pm$ 3 $^{\circ}$ C)
Indicator		Green Indicator : OUT1 & Red Indicator : OUT2
Environment	Enclosure	IP40
	Ambient temp. range	Operation: 0 ~ 50 $^{\circ}$ C, Storage: -20 ~ 60 $^{\circ}$ C (No condensation or freezing)
	Ambient humidity range	Operation/Storage: 35 ~ 85% RH (No condensation)
	Withstand voltage	1000V AC in 1-min
	Insulation resistance	50M $\Omega$ (at 500V DC)
	Vibration	Total amplitude 1.5mm, 10Hz-55Hz-10Hz scan for 1 minute, two hours each direction of X, Y and Z
Shock		980m/s <sup>2</sup> (100G), 3 times each in direction of X, Y and Z
Temperature characteristic		$\pm$ 2% F.S. of detected pressure (25 $^{\circ}$ C) at temp. Range of 0~50 $^{\circ}$ C
Port size		G1/8", M5
Connector		M84QD
Weight		Approx. 29.8g

**ORDERING INFORMATION**

**PSA100C**



Vacuum (0.00~-1.00bar) / 2 PNP output / G1/8" / M8, 4Pin male connector

**OUTPUT CIRCUIT WIRING DIAGRAMS**

PNP output

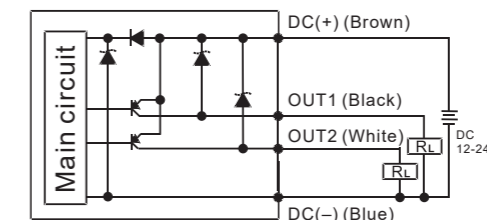

**PANEL DESCRIPTION**

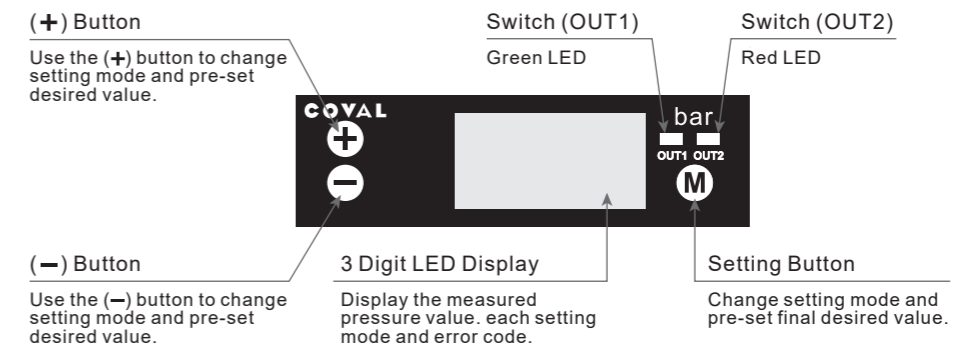

**DIMENSIONS**

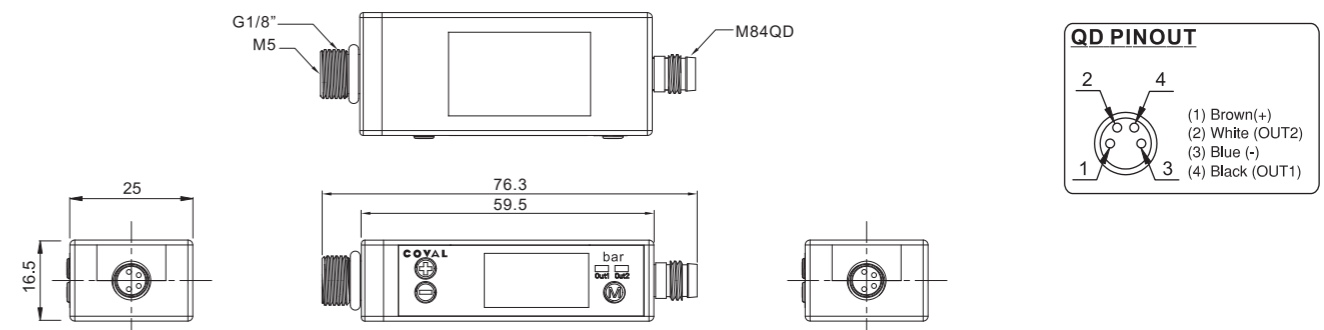

Unit:mm

## SETTING STEPS

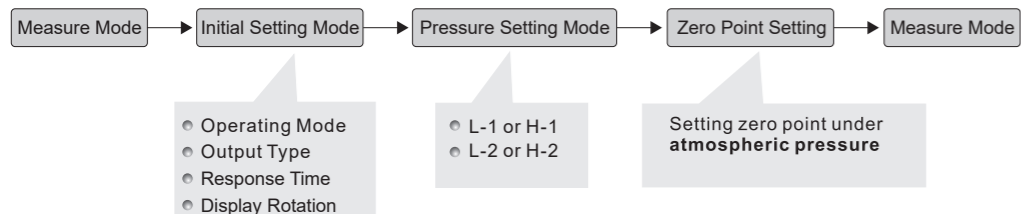

## INITIAL SETTING MODE

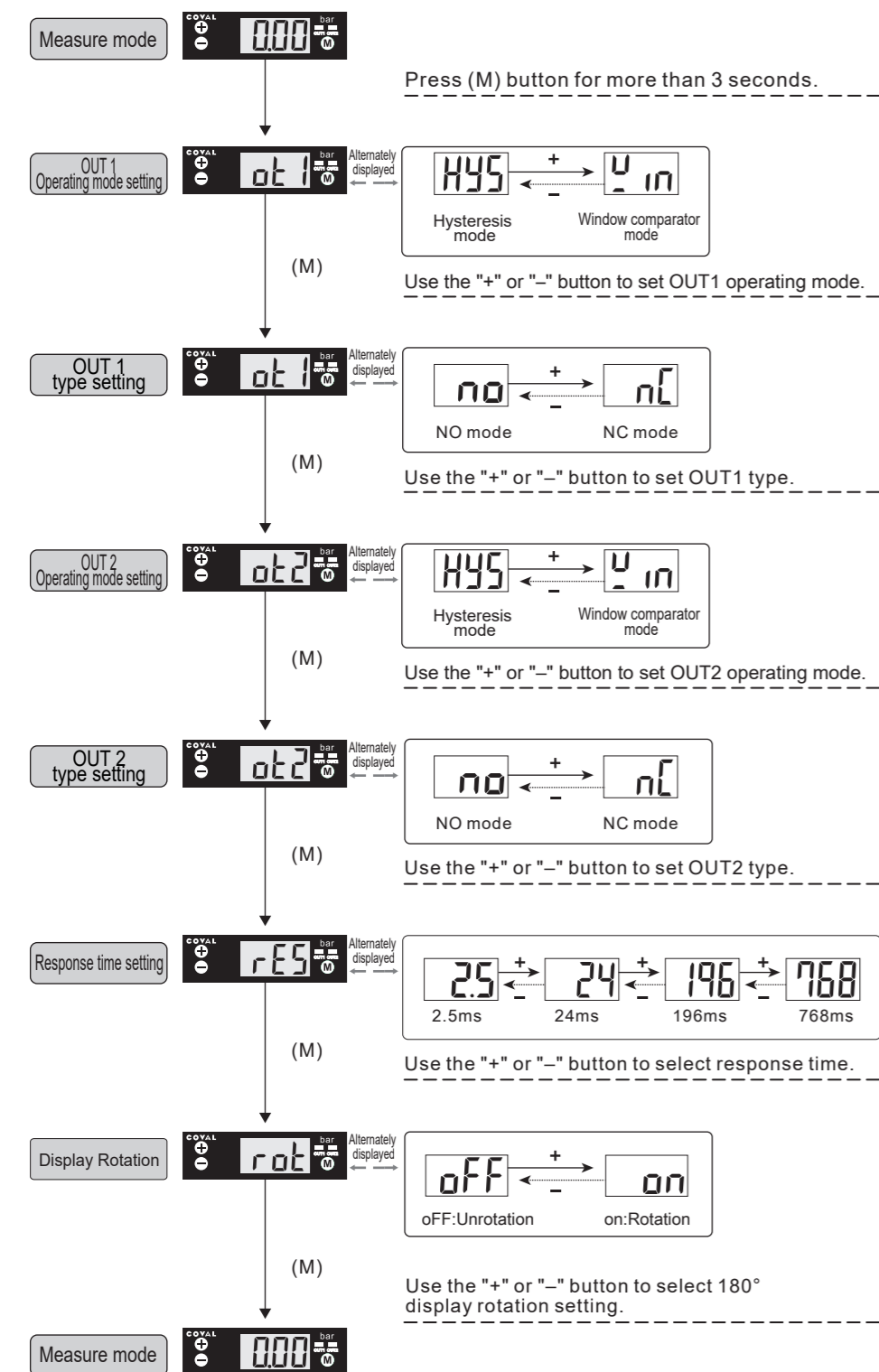

## OUTPUT TYPE

Hysteresis mode:

**Normal open mode**

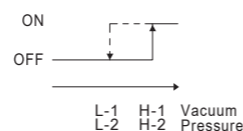

**Normal close mode**

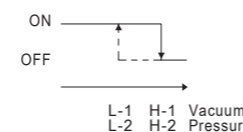

Window comparator mode:

**Normal open mode**

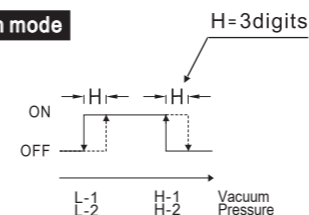

**Normal close mode**

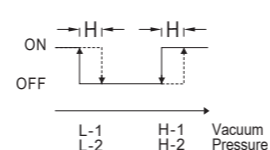

**[Note :]** When hysteresis mode setting is within 2 digits, if the input and pre-set pressure is quite near, pressure sensor output might cause chattering.

**[Note :]** Hysteresis is fixed in 3 digits. Pressure value level setting : At least 6 digits.

## ZERO POINT SETTING

Use the + and - button at the same time until the "00" is shown, Release the button to end zero setting.



## PRESSURE SETTING MODE

© Hysteresis mode / Window comparator mode:

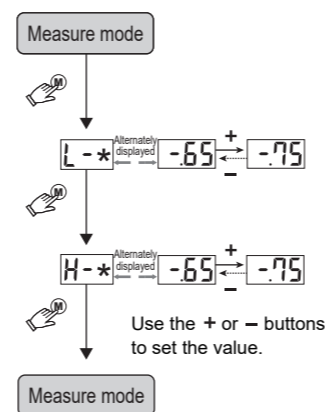

\*When out 1, "\*" displays 1  
When out 2, "\*" displays 2.

## THE MAX. & MIN. DISPLAY MODE

© The Max. value display mode:

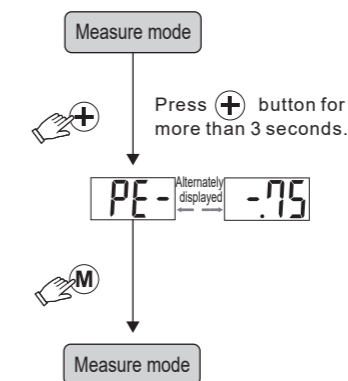

© The Min. value display mode:

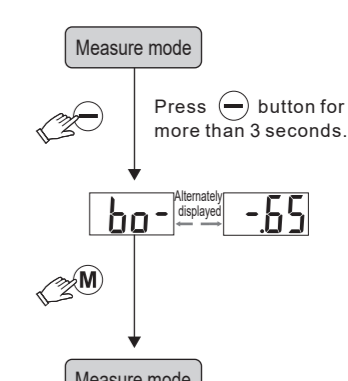

## KEY LOCK/UNLOCK MODE

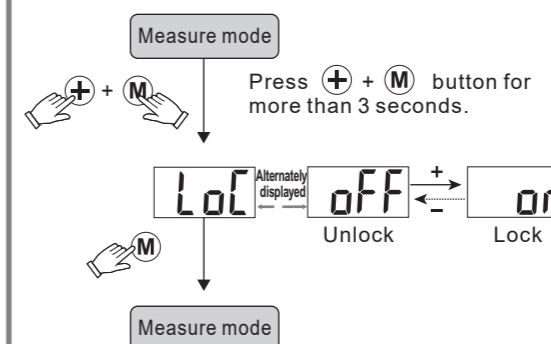

© Key lock mode, it displays as picture when pressing any key. After some time, it would be returned to measure mode.



## ERROR CODE INSTRUCTION

Error Name	Error code	Error instruction	Troubleshooting
Excess load current error	OUT1 Er1	Excess load current of 125 mA	Turn power off and check the cause of overload current or lower the current load under 125 mA, then restart.
	OUT2 Er2		
Residual pressure error	Er3	During zero reset, ambient pressure is over ±3% F.S.	Change input pressure to ambient pressure and perform zero reset again.
Applied pressure error	HHH	The applied pressure is excess the upper limit of pressure setting.	Adjust the pressure within applied pressure range.
	LLL	The applied pressure is excess the lower limit of pressure setting.	
System error	Er4	Internal data error	Turn power off, and then restart. If error condition remains, please return to factory for inspection.
	Er6	Internal system error	
	Er7	Internal data error	
	Er8	Internal system error	