

# QR

## Quick Release Device

### Quick Release



Economic solution developed especially for micro ejectors to respond to applications requiring a quick release back to atmospheric pressure of a vacuum network with reduced space and weight.

Operating:

When the ejector is pressurized to generate vacuum it applies to the internal valve of the QR18 and blocks atmospheric evacuation. When the pressure is interrupted to stop vacuum generation, the network is automatically vented to atmosphere.

#### Advantages

- Allows a quick and automatic release to atmosphere of a vacuum network.
- Reduces cycle times
- Avoids the addition of a blow-off distributor.
- Check valve control synchronized with ejector's supply
- No energy consumption
- Easy disassembly for cleaning

#### Specifications

Model	Fitting	Weight (g)
QR18	G1/8"	35

- Pressure connection by G1/8" female fitting
- Connection to vacuum network by G1/8" male thread
- Operating pressure: 2 to 7 bar
- Release rate to atmosphere: about 5.30 SCFM
- Nominal diameter : 4mm
- Materials : aluminium, nitrile (NBR), brass, steel
- Operating temperature : 32 to 122°F

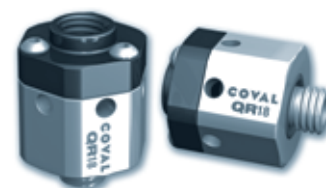

#### Dimensions

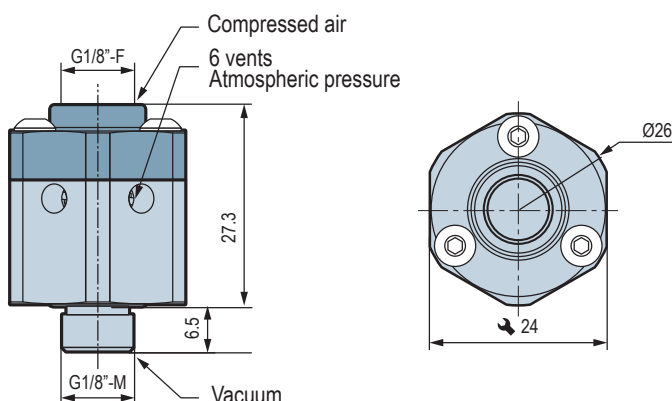

#### Pneumatic assembly

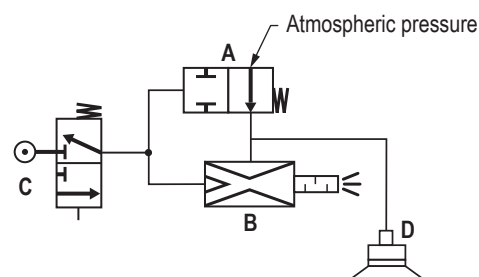

- A: QR18 Quick Release device
- B: Ejector (Venturi).
- C: Compressed air distributor
- D: Vacuum network



Specify the part number: QR18  
Please refer to the characteristics table above

Note: All dimensions are in mm