

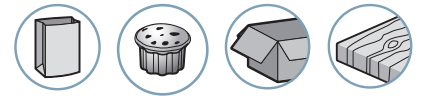

The TCL Series side-channel blowers, thanks to their high suction capacities, allow the handling of cartons, mousses, or other porous materials.

Industry-specific applications



### Advantages

- High suction capacity
- Vibration-free
- Maintenance-free: self-lubricated bearings, contactless impeller
- Integrated safety valve (optional)
- Wide range of vacuum to meet specific applications

### Characteristics

Models	Hz	ft <sup>3</sup> /min	Vacuum (%) <sup>1</sup>	kW	Number of stages	Voltage (V) <sup>2</sup>	Intensity (A)	dB(A) <sup>3</sup>	Weight (g)
TCL210T40A2S	50	123.6	39	4.0	2	345-415 Δ / 600-720 Y	10 Δ / 5.8 Y	72	44
	60	147.1	41	4.6		380-480 Δ / 660-720 Y	9.9 Δ / 5.71 Y	74	44
TCL315T43A2S	50	185.4	36	4.3	2	345-415 Δ / 600-720 Y	10 Δ / 5.2 Y	73	54
	60	220.7	32	4.8		380-480 Δ / 660-720 Y	10.4 Δ / 6 Y	76	54
TCL530T75A2S	50	311.9	40	7.5	2	345-415 Δ / 600-720 Y	16.7 Δ / 9.6 Y	74	86
	60	364.9	36	8.6		380-480 Δ / 660-720 Y	17.3 Δ / 10 Y	78	86
TCL1050T125B1S	50	618	29	12.5	1	345-415 Δ / 600-720 Y	28 Δ / 16.2 Y	74	116
	60	735.7	27	14.5		380-480 Δ / 660-720 Y	29 Δ / 16.7 Y	79	116

(1) Relief valves are available for limiting differential pressure

(2) Other voltages are available on request

(3) Noise level measurement acc. to EN ISO 3744 at a distance of 1m with hoses connected

### Specifications

Degree of electrical protection	IP55
Thermal class	ISO F
Certifications	CE, UL and CSA
Materials	Housing and impeller made of die-cast aluminium
Ambient temperature	-77°F to +104°F

### Accessories on demand:

- Safety valve
- Reversing valve
- Sound proofing box

 Specify the part number: **TCL210T40A2S**  
Please refer to the characteristics table above



### Suction flow (m<sup>3</sup>/h) / Vacuum (%)

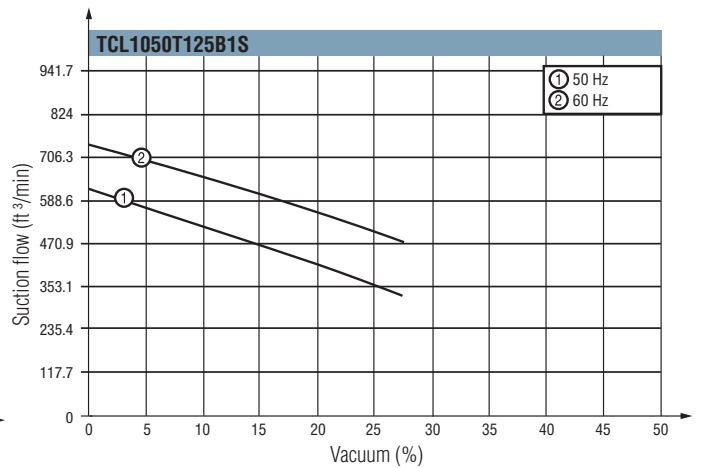
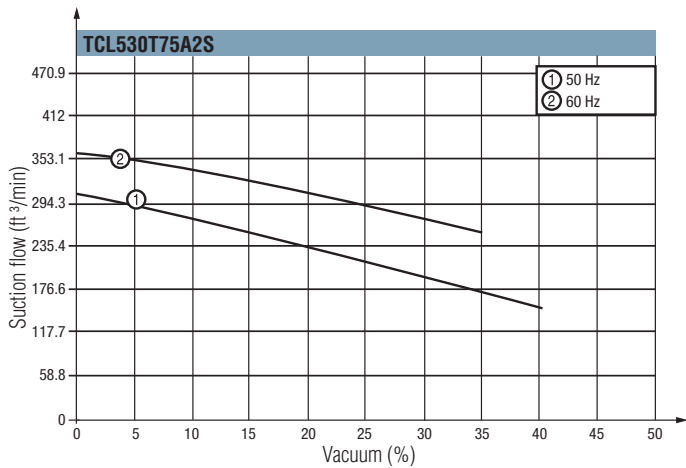
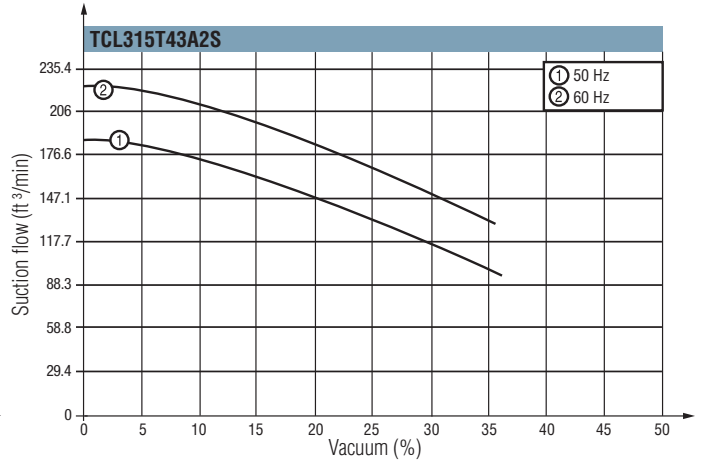
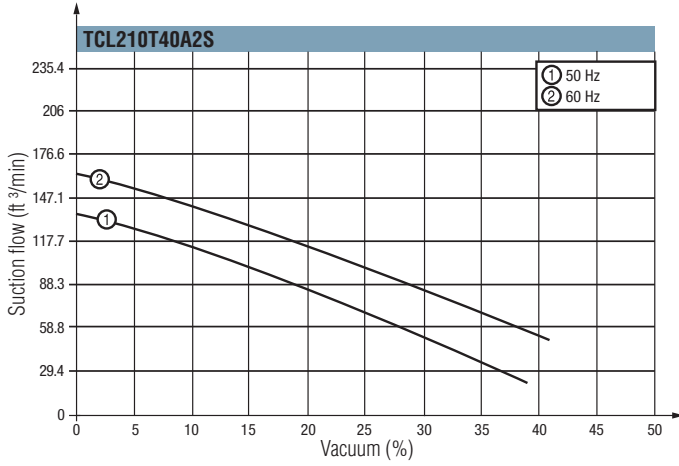

Curves are valid for continuous operation; medium: air at 59°F, measured at inlet port and atmospheric back pressure of 1013 hPa (mbar abs.), Tolerance: ± 10%; ambient temperature : -77°F to +104°F

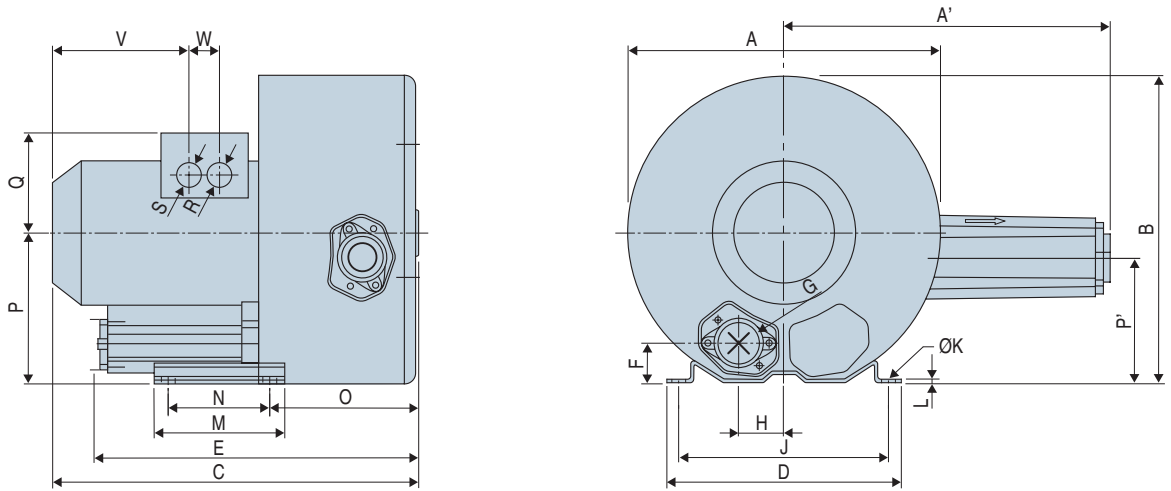

Models	A	A'	B	C	D	E	F	G	H	J	K	L	M	N	O	P	P'	Q	R	S
TCL210T40A2S	372	431	361	500	295	404	48	G 2"	60	260	14	4	155	115	171	175	144	135	4xM32x1.5	
TCL315T43A2S	426	426	420	526	325	449	54	G 2"	63	290	15	4.5	180	140	205	198	164	148	4xM32x1.5	
TCL530T75A2S	500	579	491	589	394	575	66	G 2 1/2"	76	356	15	6	217	170	236	241	200	167	4xM32x1.5	

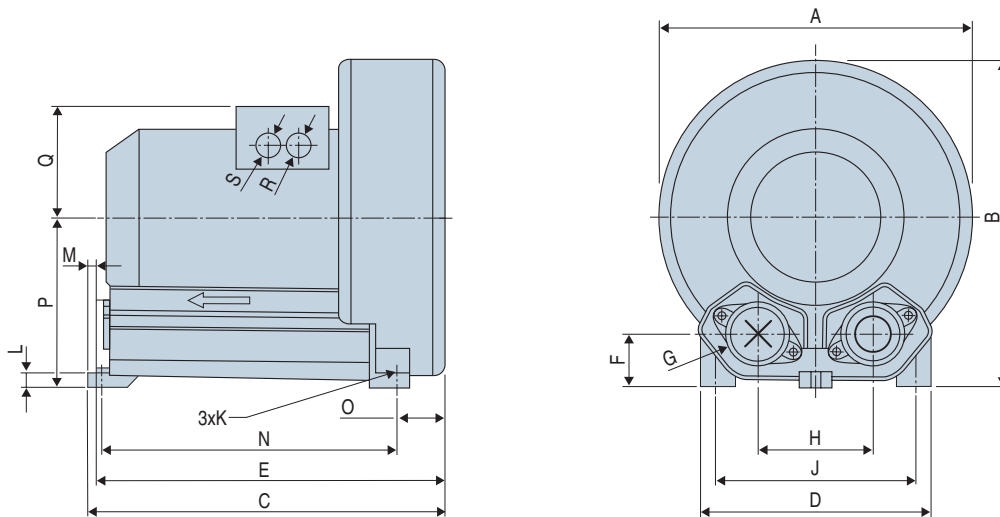

Model	A	B	C	D	E	F	G	H	J	K	L	M	N	O	P	Q	R	S
TCL1050T125B1S	560	579	645	412	613	92	G 4"	207	360	15	21	39	533	89	300	197	4xM32x1.5	

Dimensions in mm  
The values are representative of the average characteristics of our products.