

VPSC

Ultra-Flat, Non-Marking Suction Cups

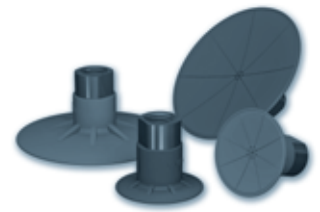

Industry-specific applications



Types of use



Developed through partnerships with the composite material industry, the VPSC suction cups are dedicated to the handling of raw composite. Their ultra-flat profile and innovative system of vacuum distribution across the surface of the cups provide optimized gripping with no mark and no deformation. The extra thin sealing lip contours to the product shape without restriction.

The specific characteristics of these suction cups enable its use in other fields such as cheese handling or other fragile, easily deformed products.

The VPSC cups are available in two materials to meet all the applications:

- Polyurethane (PU), high resistance to hydrocarbons and high durability.
- Silicone (SIBL5), food compliance. FDA and CE 1935/2004 standards.

The VPSC suction cups are equipped with a G1/4" female pressed aluminum fitting.

3



VPSC

Materials

PU Polyurethane 60 Shore A

SIBL5 Blue Silicone 50 Shore A

Suction Cup Characteristics



	Ø (mm)	Volume (cm ³)	Force (N) ⁽¹⁾	Force (N) ⁽¹⁾	PU	SIBL5
 VPSC 40	40	5.6	27	15	VPSC40PUIF14	VPSC40SIBL5IF14
 VPSC 80	80	11.2	92.6	46.3	VPSC80PUIF14	VPSC80SIBL5IF14

(1) Actual force of the suction cup in use with 65% vacuum and including a safety factor of 2 for horizontal handling and a factor of 4 for vertical handling.

When used on deformable materials, the indicated forces may require more consideration. Please contact us, particularly for composite applications.

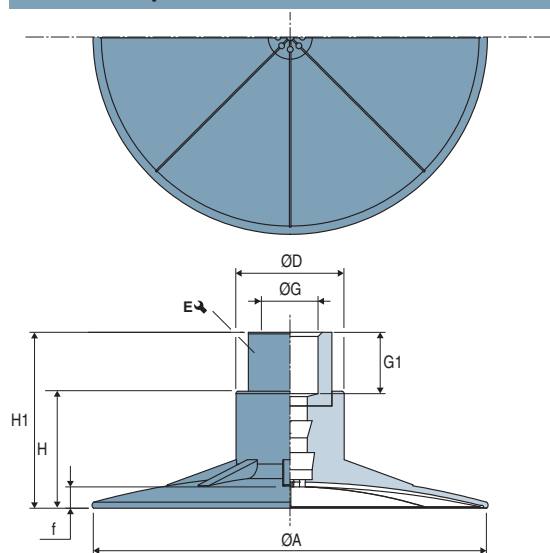
Suction Cup Dimensions



	Ø A	Ø D	f ⁽²⁾	H	H1	Ø G	E 	Weight (g)
 VPSC 40	40	21	1.5	21.8	33.8	G1/4"-F	17	16
 VPSC 80	80	22	4	23.8	35.8	G1/4"-F	17	26

(2) f = Deflection of the suction cup.



Specify the part number e.g.: **VPSC80PUIF14**
Please refer to the characteristics table above

The values represent the average characteristics of our products.
Note: All dimensions are in mm