

# VRU

## Vacuum Rotary Union

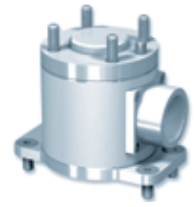

The VRU Series Vacuum Rotary Union, with its robust and lightweight design, provides a direct connection between the robot and the gripper, while also allowing an external vacuum supply to the gripper.

Its continuous rotation system avoids coiling of the hose and eliminates force constraints when used with collaborative robots.

Industry-specific applications



### Advantages

- Compact and lightweight
- Excellent mechanical resistance
- Easy integration: Mounting interface: ISO 9409-1-50-4-M6
- Continuous rotation
- Ideal for cobotic

### Characteristics

Model	Flow Rate (SCFM)	Connection	⚖️ (g)
VRU34A50	52.97	G3/4"-F	440

### Specifications

Materials	Steel - Aluminum - POM - Brass - NBR Nitrile
Temperature range	From 14 to 122 °F

### Dimensions

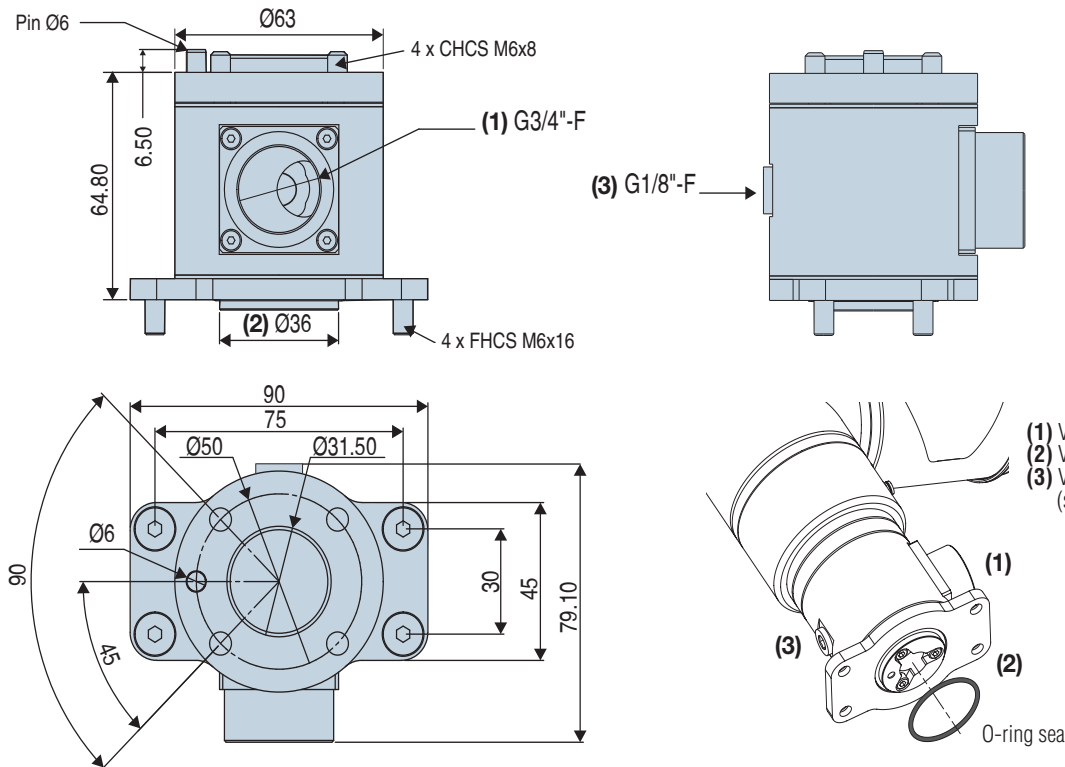

Note: All dimensions are in mm.  
The values represent the average characteristics of our products.



To order please specify: VRU34A50

### Accessory

G3/4" on-line rotating seal, part n° VRS34MF